



IO-APIS-...-IHX-...

APLISENS

MANUFACTURER OF INDUSTRIAL MEASURING
INSTRUMENTATION AND CONTROL ELEMENTS





USER'S MANUAL

ELECTROPNEUMATIC POSITIONER
Type APIS

MARCH 2026, OSTROW WLKP.

APLISENS S.A., 03-192 Warsaw
tel. +48 22 814 07 77; fax +48 22 814 07 78
www.aplisens.pl, e-mail: aplisens@aplisens.pl

Marking used

| Symbol | Description |
|---|--|
|  | Warning to strictly follow information included in the documentation to ensure safety and functionality of the device. |
|  | Information particularly useful during assembly and operation of the device. |
|  | Information particularly useful during assembly and operation of the Ex device. |
|  | Information on procedures for used equipment |

BASIC REQUIREMENTS AND OPERATIONAL SAFETY



- **The manufacturer shall not be liable for damages resulting from the incorrect installation, not maintaining in adequate condition and misuse of the positioner.**
- Assembly works and start-up should be carried out only by the qualified fitters, control engineers or trained personnel under their supervision, in accordance with applicable regulations and recommendations within the scope of control of electrical engineering.
- Incorrect installation or configuration may cause incorrect operation, leading to damage of the equipment or to an accident.
- All safety and protection requirements should be taken into consideration during installation, operation, inspections.
- The device should be disconnected in case of inoperability and sent to the manufacturer or authorized centre for repair.



Systems for intrinsically safe executions should be made with a due care and with strict observations of the standards and regulations applicable for these types of the system.

Amendments introduced in the product manufacturing documentation may be ahead of the user's paper documentation - valid user's manuals are available on the website of the manufacturer: www.aplisens.pl



ELECTROPNEUMATIC POSITIONER
TYPE APIS-...-REx-...-IHX-...
INTRINSICALLY SAFE VERSION

1. Introduction

- 1.1. This “annex Exi” applies only to the intrinsically safe version of the APIS positioners with marking on the rating plates as in point 3 of the annex and information on the Ex version in the “Product certificate”.
- 1.2. The above-mentioned annex contains supplementary information connected with the intrinsically safe version of the positioners. During installation and use of the positioners in the Ex version you should use IO APIS-...-IHX-... with the “Annex Exi”.

2. Use of the positioners listed in point 1 in hazardous areas

- 2.1. The above-mentioned positioners are executed in accordance with the requirements of the standards: EN 60079-0, EN 60079-11
- 2.2. The positioner can be operated in hazardous areas in accordance with the marking of explosion proof design:



 II 2G Ex ia IIC T5/T6 Gb
KDB 17ATEX0035

- 2.3. Category of the positioner and hazardous area.
Category included in the marking of the 2G positioner informs that the positioner can be installed in hazardous area 1.

3. Identification marking

The intrinsically safe APIS positioner is equipped with two plates:

- a) rating plate, with information provided in point 4. IO – APIS-...-IHX-....
- b) with additional plate with the following data:
 - type of the positioner and company logo
 - CE mark and notified body number sign, mark 
 - marking of explosion-proof marking and certificate marking
 - parameters Ui, li, Ci, Li, Pi
 - operating temperatures

4. Completeness of the delivery

Recipients receives the positioners in Ex version in unit package and/or bulk shipping box with documents in accordance with point 2 of the IO – APIS-...-IHX-... user’s manual. Furthermore, the recipient may obtain a copy of the certificate on request (available also on the website www.aplisens.pl).

5. Allowable input and output parameters (based on the data from the annexes to KDB 17 ATEX 0035 certificate and certification documentation)

The positioners should be supplied from associated supply and measuring equipment having appropriate certificates of intrinsic safety, which parameters of outputs to hazardous areas should not exceed allowable supply parameters for the positioners as given below:

5.1. Allowable input parameters - applies to all versions of APIS-...-REx-...-

| | | Supply characteristics | | | | | | Ci, Li |
|-------------|--------------------|-----------------------------|-------------------------------|-------------------------------|--------------------------------|------------------------------|--|--------------------------------|
| | | Linear | | Rectangular | | Trapezoidal | | |
| Temp. class | Terminals | T5 | T6 | T5 | T6 | T5 | T6 | |
| | 1,2 (SP input) | $U_i = 30V$ | $U_i = 30V$ | $U_i = 24V$ | $U_i = 24V$ | $U_i = 24V$ | $U_i = 24V$ | $C_i = 11nF$ $Li = 0,205mH$ |
| | 7,8 (PV output) | $I_i = 0,13A$ $P_i = 1W$ | $I_i = 0,1A$ $P_i = 0,75W$ | $I_i = 0,05A$ $P_i = 1,2W$ | $I_i = 0,025A$ $P_i = 0,6W$ | $I_i = 0,1A$ $P_i = 1,2W$ | $I_i = 0,05A$ $P_i = 0,6W$ $U_q = 48V$ | |

5.2. Output parameters – applies to APIS-XX1, APIS-XX2, APIS-XX3, APIS-XX4

| Terminals | Parameters |
|--|--|
| 3,4,5 (Input for external position encoder) | $U_o = 6V$ $I_o = 75mA$ $P_o = 0,12W$ $C_o = 2,5\mu F$ $L_o = 0,7mH$ |

5.3. Allowable input parameters - applies to APIS-XX0-...-REx-...-S2

| | | Supply characteristics | | | Ci, Li |
|-------------|-------------------------|--------------------------------|---------------------------------|--|--------------------------------|
| | | Linear | Rectangular | Trapezoidal | |
| Temp. class | Terminals | T5, T6 | T5, T6 | T5, T6 | |
| | 3,4 (Limit switch 1) | $U_i = 15V$ | $U_i = 15V$ | $U_i = 15V$ | $C_i = 31nF$ $Li = 0,216mH$ |
| | 5,6 (Limit switch 2) | $I_i = 0,025A$ $P_i = 0,1W$ | $I_i = 0,004A$ $P_i = 0,06W$ | $I_i = 0,008A$ $P_i = 0,06W$ $U_q = 30V$ | |

5.4. Permissible operating temperature range

| Operating temperature range | Temperature class | |
|-----------------------------|---------------------------------------|---------------------------------------|
| | T5 | T6 |
| | $-40^\circ C \leq t \leq +80^\circ C$ | $-40^\circ C \leq t \leq +45^\circ C$ |

6. Connection method for the electrical APIS positioners in Ex version.



Connections of the positioner and equipment in the measuring loop of the positioner should be executed in accordance with standards applicable for intrinsic safety and explosion-proofness and conditions of use in the hazardous areas. Failure to follow the intrinsic safety rules can cause an explosion and risk to humans.

Connection methods for input and output circuit and displacement transducer are presented in point 11.4.



No repairs or other interventions in the electrical system of the positioner are allowed. Assessment of damage and possible repair should be carried out only by the manufacturer or a company authorized by this manufacturer.

TABLE OF CONTENTS

| | | |
|------------|--|-----------|
| 1. | INTRODUCTION..... | 3 |
| 2. | COMPLETENESS OF THE DELIVERY..... | 3 |
| 3. | INTENDED USE..... | 3 |
| 4. | IDENTIFICATION MARKING..... | 3 |
| 5. | TECHNICAL DESCRIPTION..... | 4 |
| 5.1. | PRINCIPLE OF OPERATION..... | 4 |
| 5.2. | DESIGN..... | 4 |
| 5.3. | DIAGNOSTICS..... | 6 |
| 5.4. | ANALOG OUTPUT..... | 6 |
| 5.5. | ELECTRONIC LIMIT SWITCHES..... | 6 |
| 5.6. | DIMENSIONS OF POSITIONER..... | 7 |
| 5.7. | ORDERING CODE FOR THE APIS POSITIONER..... | 8 |
| 6. | TECHNICAL DATA..... | 9 |
| 7. | OPERATING CONDITIONS..... | 10 |
| 8. | TRANSPORT GUIDELINES..... | 10 |
| 9. | INSTRUCTIONS FOR UNPACKING AND STORAGE..... | 11 |
| 10. | ASSEMBLY MANUAL..... | 11 |
| 10.1. | GENERAL RECOMMENDATIONS..... | 11 |
| 10.2. | ASSEMBLY OF THE POSITIONER ON ACTUATOR 37 AND 38 MANUFACTURED BY POLNA S.A. – VERSION APIS-A1X0-... WITH MOUNTING KIT APIS A0001-SS OR SO TYPE P1 AND R1 MANUFACTURED BY POLNA S.A. –VERSION APIS-1X0-... WITH MOUNTING KIT APIS-A0002-SS OR SO..... | 11 |
| 10.3. | ASSEMBLY OF THE POSITIONER ON ACTUATOR TYPE P AND R MANUFACTURED BY POLNA S.A. - VERSION APIS-A1X0-... WITH MOUNTING KIT APIS-A0000-SS OR SO..... | 13 |
| 10.4. | ASSEMBLY OF THE POSITIONER ON ACTUATOR WITH A CONTROL VALVE WITH A RIB - COMPATIBLE WITH PN-EN 60534-6-1:2001 E.G. ON ACTUATOR MANUFACTURED BY SAMSON OR ARCA REGLER - VERSION APIS-1X0-... WITH A MOUNTING KIT APIS-A0003-SS OR SO..... | 14 |
| 10.5. | ASSEMBLY OF THE POSITIONER ON SINGLE OR DOUBLE OPERATING ACTUATOR WITH ROTATIONAL MOVEMENT CONFORMING EN ISO 5211, DIN 3337, VDI/VDE 38450 NAMUR E.G. ON ACTUATOR MANUFACTURED BY AIR TORQUE, EBRO ARMATUREN, EL-O-MATIC - VERSION APIS- 1X0-... AND APIS-2X0-... WITH A MOUNTING KIT APIS-A0050-SS OR SO..... | 15 |
| 10.6. | ASSEMBLY OF THE POSITIONER WITH DOUBLE ACTION ACTUATOR WITH LINEAR MOVEMENT CNOMO OR CONFORMING THE ISO 6431 E.G. ACTUATOR MANUFACTURED BY PREMA KIELCE, FESTO - VERSION APIS- 2X1-..., APIS-2X2-... WITH A MOUNTING KIT APIS-AXXXX-SS OR SO..... | 17 |
| 10.7. | ASSEMBLY OF THE POSITIONER WITH DOUBLE ACTING LINEAR ACTUATOR E.G. CNOMO SERIES OR CONFORMING WITH ISO 6431 (PREMA KIELCE OR FESTO) – VERSION APIS-2X0-... WITH A MOUNTING KIT APIS-AXXXX-SS OR SO..... | 19 |
| 10.8. | RULES OF INSTALLATION OF PNEUMATIC HOSES..... | 21 |
| 11. | USER'S MANUAL..... | 21 |
| 11.1. | GENERAL INFORMATION..... | 21 |
| 11.1.1. | CONTROL BUTTONS..... | 21 |
| 11.1.2. | POSITIONER SERVICING LEVELS..... | 22 |
| 11.2. | POSITIONER FUNCTIONS..... | 24 |
| 11.2.1. | I (1ST) SERVICE LEVEL - NORMAL OPERATION MODE..... | 24 |
| 11.2.1.1. | PV – READOUT OF ACTUAL VALUE OF DISPLACEMENT OF ACTUATOR PISTON ROD..... | 24 |
| 11.2.1.2. | SP – READOUT OF ACTUAL VALUE OF INPUT (CONTROL) SIGNAL (CURRENT)..... | 24 |
| 11.2.1.3. | T °C – READOUT OF ACTUAL INTERNAL TEMPERATURE OF THE POSITIONER..... | 25 |
| 11.2.1.4. | CP IND – CORRECT POSITION INDICATOR (ENCODER)..... | 25 |
| 11.2.1.5. | MANUAL – MANUAL CONTROL MODE FOR THE ACTUATOR - FUNCTION AVAILABLE ON DEMAND..... | 25 |
| 11.2.1.6. | VER EN X.XX – INFORMATION ON SOFTWARE VERSION OF THE POSITIONER..... | 27 |
| 11.2.2. | II (2 ND) SERVICE LEVEL - TRANSIENT MODE..... | 30 |
| 11.2.2.1. | PIIN – ACCESS PASSWORD FOR ADVANCED SOFTWARE AND CONFIGURATION FUNCTIONS OF THE POSITIONER..... | 30 |
| 11.2.3. | III (3 RD) SERVICE LEVEL – CONFIGURATION AND PARAMETERS SETTINGS MODE..... | 32 |
| 11.2.3.1. | PV – READOUT OF ACTUAL VALUE OF DISPLACEMENT OF ACTUATOR PISTON ROD..... | 32 |
| 11.2.3.2. | AUTO – AUTOMATIC TUNING OF POSITIONER SETTINGS..... | 32 |
| 11.2.3.3. | KP – GAIN KP OF THE PID CONTROLLER..... | 34 |
| 11.2.3.4. | Ti – INTEGRAL ACTION TIME OF THE PID CONTROLLER..... | 35 |
| 11.2.3.5. | Td – DERIVATIVE ACTION TIME OF THE PID CONTROLLER..... | 36 |
| 11.2.3.6. | RAMP – SPEED OF ACTUATOR PISTON ROD..... | 37 |
| 11.2.3.7. | STROKE – AUTOMATIC DETERMINATION OF STROKE OF PISTON ROD OF THE ACTUATOR..... | 38 |

| | |
|---|-----------|
| 11.2.3.8. SP LO – SETTING OF MINIMUM VALUE OF CURRENT CONTROL SIGNAL | 40 |
| 11.2.3.9. SP HI – SETTING THE MAXIMUM VALUE OF CURRENT CONTROL SIGNAL | 41 |
| 11.2.3.10. DOWN – DISPLACEMENT OF ACTUATOR PISTON ROD TO THE FIRST BUMPER | 42 |
| 11.2.3.11. UP – DISPLACEMENT OF THE ACTUATOR PISTON ROD TO THE SECOND BUMPER..... | 43 |
| 11.2.3.12. MANUAL – MANUAL CONTROL MODE FOR THE ACTUATOR..... | 45 |
| 11.2.3.13. REV IN – REVERSE OF THE INPUT SIGNAL | 46 |
| 11.2.3.14. REV OUT – REVERSE OF THE OUTPUT SIGNAL FROM THE POSITION TRANSMITTER..... | 47 |
| 11.2.3.15. PRESSA – OFFSET PRESSURE OF CHAMBER A OF THE ACTUATOR (CHAMBER CONNECTED WITH CONNECTOR „3” POSITIONER)..... | 49 |
| 11.2.3.16. PRESSB – OFFSET PRESSURE OF CHAMBER B OF THE ACTUATOR (CHAMBER CONNECTED WITH CONNECTOR „2” POSITIONER)..... | 51 |
| 11.2.3.17. LIMIT L – SET BY SOFTWARE THE LOWER LIMIT OF PISTON ROD POSITION | 52 |
| 11.2.3.18. LIMIT H – SET BY SOFTWARE THE UPPER LIMIT OF PISTON ROD POSITION..... | 53 |
| 11.2.3.19. CLAMPL - CLAMPING OF VALVE (FLAP) SEAT IN THE FIRST BUMPER POSITION OF THE ACTUATOR PISTON ROD | 54 |
| 11.2.3.20. CLAMPH - CLAMPING OF VALVE (FLAP) SEAT IN THE SECOND BUMPER POSITION OF THE ACTUATOR PISTON ROD...56 | |
| 11.2.3.21. _LIMSWI – LOWER LIMIT SWITCH ACTIVATION LEVEL – NO.1..... | 57 |
| 11.2.3.22. _LIMSWI – UPPER LIMIT SWITCH ACTIVATION LEVEL – NO.2 | 58 |
| 11.2.3.23. NEWPIN – ENTERING A NEW NUMERICAL PASSWORD (PIN) | 59 |
| 11.2.3.24. END – THE END OF SETTINGS OF THE PARAMETERS AND CONFIGURATION OF THE POSITIONER | 60 |
| 11.3. STARTING POSITIONER - ACTUATOR ASSEMBLY | 60 |
| 11.4. ELECTRICAL CONNECTIONS OF THE POSITIONER..... | 69 |
| 11.4.1. ELECTRICAL WIRING DIAGRAM OF POSITIONER FOR THE EXECUTIONSWITH BUILD-IN (INTERNAL) DISPLACEMENT TRANSDUCER APPLIES FOR EXECUTIONS APIS-XX0-..... | 69 |
| 11.4.2 ELECTRICAL WIRING CONNECTIONS OF THE POSITIONER FOR EXECUTION WITH EXTERNAL DISPLACEMENT TRANSDUCER (APPLIES FOR EXECUTIONS APIS-XX1-..., APIS-XX2-..., APIS-XX4-...) | 69 |
| 11.4.3 ELECTRICAL WIRING CONNECTIONS OF THE POSITIONER FOR EXECUTION WITH LIMIT SWITCHES (APPLIES FOR VERSIONS APIS-XX0-...-S2, APIS-XX0-...S3) | 72 |
| 11.5. OPERATION | 73 |
| 11.6. DISASSEMBLY OF THE POSITIONER | 73 |
| 12. MAINTENANCE..... | 73 |
| 13. FAILURES AND REPAIRS | 74 |
| 14. SPARE PARTS..... | 75 |

1. INTRODUCTION

This user's manual is a document intended for users of the electropneumatic positioners, type APIS, containing technical data and guidelines necessary to familiarize with principles of operation and method of setting of the positioners. It includes also necessary guidelines concerning the installation and operation as well as procedures in case of a fault.

2. COMPLETENESS OF THE DELIVERY

Recipients receives the positioners in unit packages and/or bulk shipping boxes.

Together with the positioner the user will obtain:

- a) "Product certificate", which is used also as a warranty card,
- b) User's manual marked IO-APIS-...-IH-...,
- c) Declaration of conformity - on request
- d) Blanking plug 1 piece

Items b), c) are also available on the website www.aplisens.pl

3. INTENDED USE

The APIS positioner is a final control element intended for control valves.

It is intended for cooperation with pneumatic membrane and piston single and double-acting actuators with linear and rotational movement. It allows quick and precise controlling of displacement of actuator piston rod using analog or digital control signal.

The positioner is controlled by a standard signal from two-wire 4..20 mA DC current loop or digitally in accordance with the HART 6 specification. It can be also equipped with a two-wire, current (4..20 mA DC) position transmitter of piston rod of the associated actuator. Current circuit of position transmitter is galvanically isolated from the input circuit of the control signal.

The positioner can cooperate both with straight and reverse acting pneumatic actuators.

The positioner can cooperate with single-acting actuators manufactured by Polna S.A., Samson, Arca Regler, Spirax-Sarco and double-acting actuators manufactured by Prema Kielce, Air Torque, Festo, Ebro Armaturen, EI-0-Matic and by other manufacturers using proper mechanical coupling components.

Electronic module of the positioner allows the user to set the parameters. These parameters include among others:

- value of proportional gain,
- integral action time,
- derivative action time of internal
- limits for movement speed of actuator piston rod

4. IDENTIFICATION MARKING

Each positioner is equipped with the rating plate with the following information: CE mark, name of the manufacturer, type marking of the positioner, serial number, supply pressure, input signal, output signal, type of actuator/stroke and year of manufacture. Information on the Ex marking are additionally given for the intrinsically safe version. See the Annex Exi for the detailed identification marking.

Ordering code and types of execution acc. to point 5.7.

5. TECHNICAL DESCRIPTION

5.1. Principle of operation

The positioner is build around 16-bit microcontroller. It performs appropriate of measurements and determines value of set-point **SP** and process value **PV**.

The difference of **SP** and **PV** values is converted in accordance with the control algorithm to a control signal (Fig. 1). This signal is converted in the electropneumatic converter to the pneumatic output signal, which is measured by an optional pressure sensor. The pneumatic signal is fed to the actuator chamber causing the actuator movement in such a direction that the difference between the **SP** and **PV** values decreases.

Positioner is supplied from a standard 4...20 mA DC current loop. For versions with optional analog position transmitter it is required to use the additional external source of supply voltage 11...36 V DC.

HART communication may require the serial connection of resistor with $250 \Omega \leq R \leq 500 \Omega$ in the line of control signal.

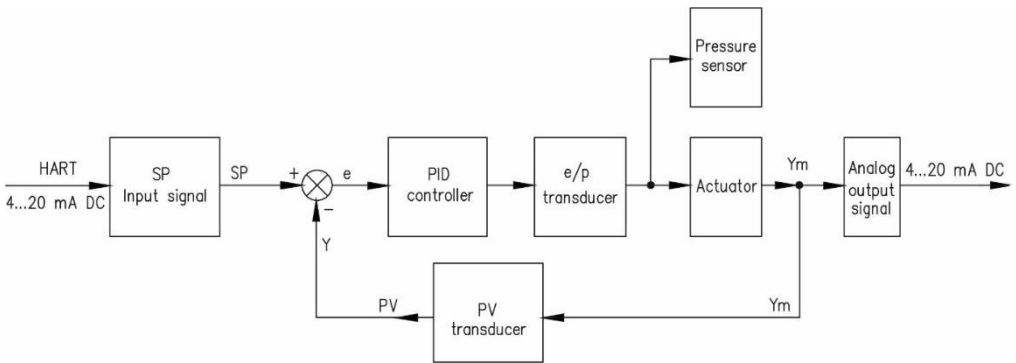

Fig. 1. Block diagram of the positioner control system

5.2. Design

APIS electropneumatic positioner consists of the following components (see Fig. 2a and 2b):

- electronic unit,
- electropneumatic transducer or transducers,
- internal or external displacement transducer for piston rod movement,
- pressure sensor (option),
- housing body*,
- cover*,
- pneumatic connections*,
- mechanical coupling unit*,
- pressure gauges.

(* units not presented in Fig. 2a and 2b)

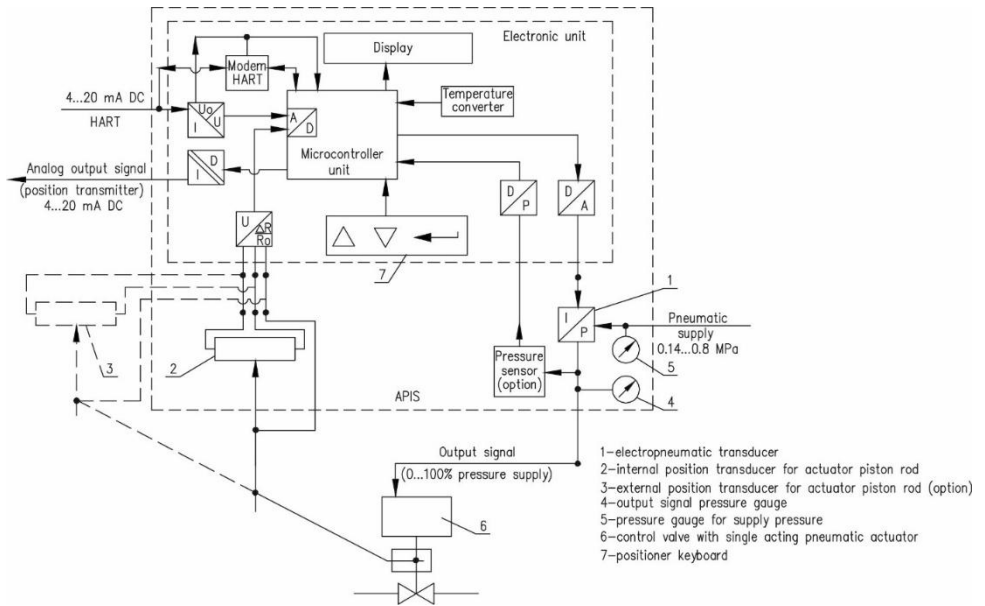

Fig. 2a. Block diagram of the APIS positioner for single-acting actuator

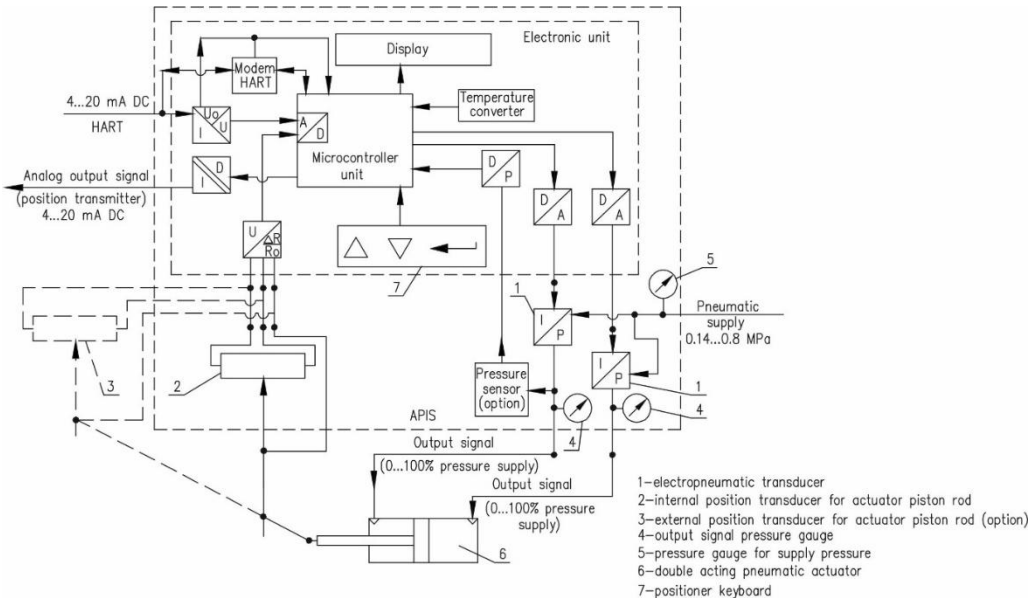

Fig. 2b. Block diagram of the APIS positioner for double-acting actuator

The electronic unit consists of:

- microcontroller,
- keyboard,
- converters: analog to digital and digital – to - analog,
- voltage-current transformer
- pressure-digital transducer,
- liquid crystal display,
- temperature transmitter,
- HART modem,
- electrical connectors.

The above-mentioned units are placed on the printed board covered with a layer of silicone and insulating varnish. The electronic unit is connected with electrical conductors with electropneumatic transducer (transducers) and a pressure sensor.

The electropneumatic converter (transducers) and pressure sensor are screwed to the body of positioner's housing. The housing body is closed with a tight cover from the side of the keyboard and electrical connectors. For APIS-XX1-., APIS-XX2-., APIS-XX3-., APIS-XX4-. the displacement transducer is installed outside the housing of the positioner. The positioner housing consisting of the body and cover has an ingress protection against environmental ingress IP65, which means that it is dust-tight and splash-proof.

Glands, pneumatic connectors and pressure gauges are screwed into the housing body.

On request the positioner can be equipped with a mounting kit allowing installing it to any type of the actuator.

5.3. Diagnostics.

Diagnostic functions are only available for the APIS-...IHS-... versions. A detailed description can be found in a separate manual: "Diagnostics in APIS Positioners."

5.4. Analog output.

The positioner is optionally equipped with an analog output for position feedback.

This is a standard 4...20 mA current output.

It requires an external power supply in series with the measurement circuit, as shown in the connection diagrams. (Passive output)

This circuit is galvanically isolated from the other circuits of the positioner.

Proper output operation requires a positioner control signal (terminals 1 and 2), which powers the main circuit. In the absence of this signal or a failure in the main circuit, the analog output switches to emergency mode, setting a constant current signal of 3,5 mA.

The output's measuring range is automatically calibrated during the "AUTO" or "STROKE" functions.

A position value of PV = 0% corresponds to an output signal of I = 4 mA, and for PV = 100%, I = 20 mA.

This signal can be reversed using the "REVOUT" function.

5.5. Electronic Limit Switches.

The positioner is optionally equipped with two electronic limit switches that signal the lower and upper limit positions of the actuator.

The thresholds for each limit switch are set programmatically in the positioner menu.

These are the parameters "_LIMSWI" – lower limit switch (no. 1), and "LIMSWI" – upper limit switch (no. 2).

The thresholds are defined as a percentage of the full actuator stroke.

Proper operation of the limit switches requires a control signal from the positioner (terminals 1 and 2), which powers the main circuit.

The limit switch output signals are galvanically isolated from other positioner circuits and from each other. The limit switches are connected to the signal receiver using a two-wire standard. Depending on the version:

S2: Two NAMUR outputs PN-EN 60947-5-6

S3: Two binary open collector outputs (not applicable to the Ex version)

Limit switches are not available in positioners mounted outside the actuator.

5.6. Dimensions of positioner.

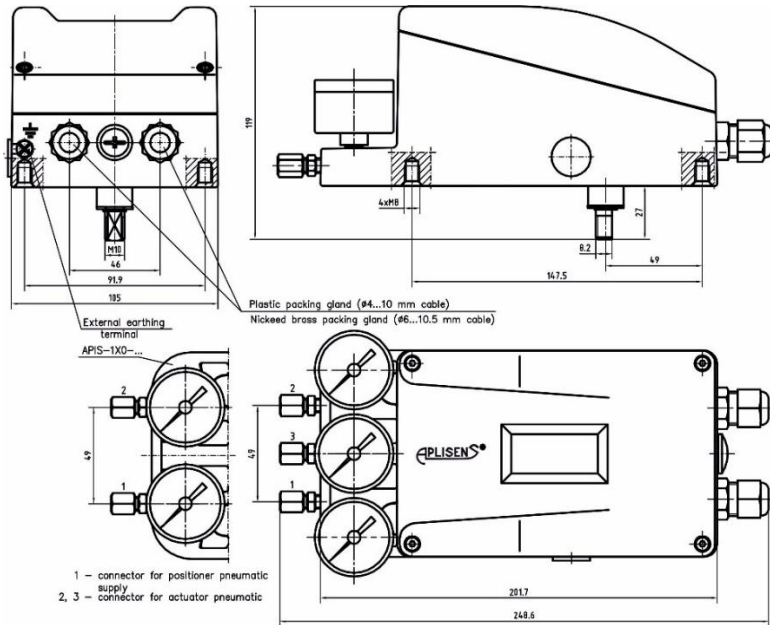

Fig.3. Dimensions of the APIS-XX0-... positioner

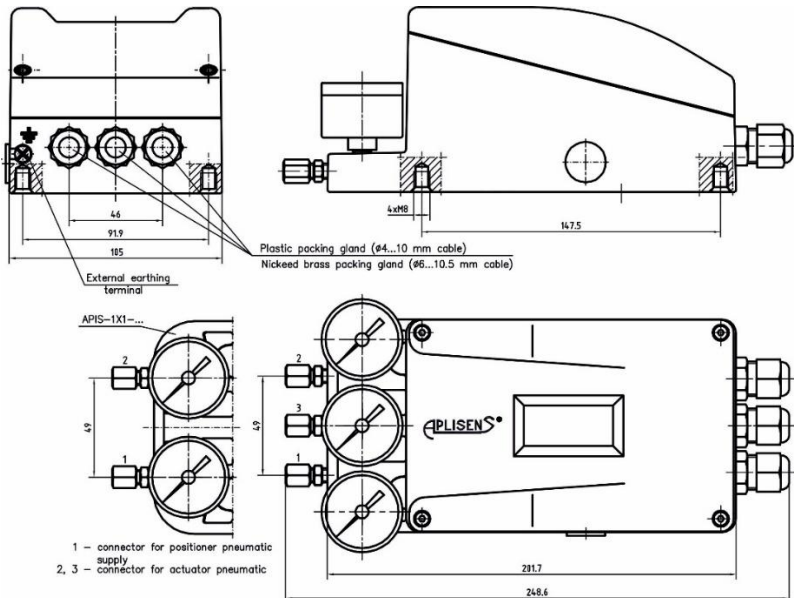



Fig.4. Dimensions of the APIS-XX1-..., APIS-XX2-..., APIS-XX3-..., APIS-XX4-... positioners

5.7. Ordering code for the APIS positioner

| | ↑ | ↑ | ↑ | ↑ | ↑ | ↑ | ↑ | ↑ | ↑ | | | | | | | | | | | | |
|--|------|---|-----|---|-----|---|-----|---|-----|---|-----|---|----|---|----|---|----|---|----|--|--|
| | APIS | - | XXX | - | DXX | - | RXX | - | IXX | - | TXX | - | PX | - | MX | - | WX | - | SX | | |
| Intend use: | | | | | | | | | | | | | | | | | | | | | |
| - for single-operating actuator | | | 1 | | | | | | | | | | | | | | | | | | |
| - for double-operating actuator | | | 2 | | | | | | | | | | | | | | | | | | |
| - for installation on actuator..... | | | 0 | | | | | | | | | | | | | | | | | | |
| - for installation outside actuator with: | | | | | | | | | | | | | | | | | | | | | |
| - external position transmitter (potentiometer) – IP54 ¹⁾ | | | | | | | | | | | | | | | | | | | | | |
| - external position transmitter (potentiometer) – IP67 ¹⁾ | | | | | | | | | | | | | | | | | | | | | |
| - external position transmitter (magnetic) – IP67 ^{1) 2)} | | | | | | | | | | | | | | | | | | | | | |
| - external position transmitter (potentiometer) – IP65 ³⁾ | | | | | | | | | | | | | | | | | | | | | |
| Distance of positioner from actuator: | | | | | | | | | | | | | | | | | | | | | |
| - in meters (0±15 m) | | | | | | | | | | | | | | | | | | | | | |
| Execution: | | | | | | | | | | | | | | | | | | | | | |
| - standard | | | | | | | | | | | | | | | | | | | | | |
| - intrinsically safe  II 2G Exia IIC T6/T5 Gb | | | | | | | | | | | | | | | | | | | | | |
| Input signal, version: | | | | | | | | | | | | | | | | | | | | | |
| - 4+20 mA with HART protocol | | | | | | | | | | | | | | | | | | | | | |
| - 4+20 mA with HART protocol and diagnostic | | | | | | | | | | | | | | | | | | | | | |
| Analog position transmitter: | | | | | | | | | | | | | | | | | | | | | |
| - without position transmitter | | | | | | | | | | | | | | | | | | | | | |
| - with output signal 4+20 mA | | | | | | | | | | | | | | | | | | | | | |
| Pneumatic connectors: | | | | | | | | | | | | | | | | | | | | | |
| - without connectors (thread Rp1/8") | | | | | | | | | | | | | | | | | | | | | |
| - connectors to brass pipes 6 mm | | | | | | | | | | | | | | | | | | | | | |
| - connectors to stainless steel pipes 6 mm | | | | | | | | | | | | | | | | | | | | | |
| - connectors to polyethylene pipes 6 mm | | | | | | | | | | | | | | | | | | | | | |
| - connectors to brass pipes 8 mm | | | | | | | | | | | | | | | | | | | | | |
| - connectors to stainless steel pipes 8 mm | | | | | | | | | | | | | | | | | | | | | |
| - connectors to polyethylene pipes 8 mm | | | | | | | | | | | | | | | | | | | | | |
| - others | | | | | | | | | | | | | | | | | | | | | |
| Pressure gauges: | | | | | | | | | | | | | | | | | | | | | |
| - with standard gauges | | | | | | | | | | | | | | | | | | | | | |
| - with stainless steel gauges | | | | | | | | | | | | | | | | | | | | | |
| Electrical entry: | | | | | | | | | | | | | | | | | | | | | |
| - plastic cable gland M16x1,5 (4÷10 mm cable) | | | | | | | | | | | | | | | | | | | | | |
| - nickeled brass cable gland M16x1,5 (6÷10,5 mm cable) | | | | | | | | | | | | | | | | | | | | | |
| Electronic limit switches (optional): ⁴⁾ | | | | | | | | | | | | | | | | | | | | | |
| - 2 digital outputs according to NAMUR EN 60947-5-6 ⁵⁾ | | | | | | | | | | | | | | | | | | | | | |
| - 2 digital open collector outputs ²⁾ | | | | | | | | | | | | | | | | | | | | | |

¹⁾ For double-operating linear actuator.

²⁾ Not available with ATEX certification.

³⁾ For single-operating linear diaphragm actuators and single or double-operating rotational actuators.

⁴⁾ Applies to direct-mount versions. Code S is not present if there are no limit switches.

⁵⁾ For the ATEX certified version, this option will be available in the second half of 2026.

Table 1. List of mounting kits

| | | |
|--|---|---|
| Mounting kit APIS-A0000-SS or SO ¹⁾ | For positioners APIS-1X0-... | For installation at column cylinder type P or R manufactured by Polna S.A. |
| Mounting kit APIS-A0001-SS or SO ¹⁾ | | For installation at actuator type 37 or 38 manufactured by Polna S.A. |
| Mounting kit APIS-A0002-SS or SO ¹⁾ | | For installation at multi-spring cylinder type P1 or R1 manufactured by Polna S.A. |
| Mounting kit APIS-A0003-SS or SO ¹⁾ | | For installation at actuator with control valve equipped with a rib - according to PN-EN 60534-6-1; 2001 e.g. on actuator manufactured by Samson or Arca Regler |
| Mounting kit APIS-A0050-SS or SO ¹⁾ | For positioners APIS-1X0 -... APIS-2X0 -... | For installation at the actuator in accordance with EN ISO 5211, DIN 3337, VDI/VDE 38450 Namur e.g.: on the actuator manufactured by Air Torque, Ebro Armaturen, EI-O-Matic |
| Mounting kit APIS-AXXXX-SS or SO ¹⁾ | For positioners APIS-2X0-... APIS-2X1-... APIS-2X2-... APIS-2X3-... | For installation at or outside the double-acting actuator with linear movement e.g.: CNOMO series or conforming ISO 6431 manufactured by PREMA KIELCE |

1) SS – material: stainless steel

SO – material: zinc-coated steel

EXAMPLE OF AN ORDER

Electropneumatic positioner intended for installation on single-acting actuator with linear movement, in standard version, with analog input signal 4÷20 mA DC and HART protocol, with position transmitter (4÷20 mA DC), with connectors to brass pipes Ø8 mm, with manometers in stainless steel housing, with packing gland (for ø4÷10 mm cables), without limit switch.

APIS-1X0-D00-RSt-IHE-T20-P4-M2-W1

Mounting kit (for installation at the actuator type 37 or 38 manufactured by Polna S.A) – **APIS-A0001-SS**.

6. TECHNICAL DATA

| | | |
|--|---|------------|
| Input (control) signal (current) | two - wire 4÷20 mA DC with Hart protocol | |
| Input load voltage at 20mA | 9,5V (corresponds to 475 Ω) | |
| Maximum duration of supply dip | 20ms | |
| Output signal (position transmitter) | 4÷20 mA DC two - wires | |
| Supply of position transmitter | 10÷36 V DC (RSt) | |
| S2 type limit switch signal: @ Uaux = 8,2V, Ri = 1kΩ | Low state: $0,7\text{mA} \leq I \leq 1,2\text{mA}$ High state: $I \geq 2,1\text{mA}$ | |
| S3 type limit switch signal: | Low state: $I \leq 25\mu\text{A}$ High state: $R = 1\text{k}\Omega$ | |
| Maximum power supply parameters for S2 and S3 type limit switches. | Version | Uaux ≤ 35V |
| | RSt: | I ≤ 25mA |
| Maximum power supply inputs and outputs parameters for Ex version | acc. to the annex Exi, point 5.1, 5.2, 5.3 | |
| Supply pressure | 140...800 kPa | |
| Pneumatic output signal | 0÷100% of supply pressure | |
| Own air consumption | < 0,035 kg/h at 140 kPa supply pressure < 0,015 kg/h at 800 kPa supply pressure | |

| | |
|--|---|
| Air mass outflow rate | > 3,25 kg/h at 140 kPa supply pressure > 13 kg/h at 800 kPa supply pressure |
| Travel range | 10÷100 mm (for single-acting linear actuators) 80÷900 mm (for double-acting linear actuators) 0÷180° (for rotational actuators) |
| Actuator operation characteristics | linear |
| Positioner operation mode | normal or reversible |
| Positioner transducer mode | normal or reversible |
| Additional positioning errors | |
| - caused by change of supply pressure | <0,05% / 100kPa |
| - caused by change of ambient temperature | 0,15% / 10°C – for temperature range -30°C...+60°C 0,25% / 10°C – for temperature range -40°C...-30°C and +60°C...+85°C |
| - caused by vibrations: 10...60Hz, amplitude < 0,35 mm 60...500Hz, acceleration ≤ 5g | 0,25% |
| Hysteresis | <0,4% |
| Sensitivity (dead band) | <0,1% |
| Degree of protection | IP 65 |
| Operation position | any |
| Weight | 1,8 kg |

7. OPERATING CONDITIONS

Positioner type APIS is intended for operation in the following conditions:

- air supply: dust free, oil free, water free air. Maximum size of solid particles not bigger than 1,5 µm. Operating temperature not lower than dew point temperature according to EN 60654-2:1999.
- ambient temperature:
 - execution without manometers and stainless steel and stainless steel wetted manometers: -40°C ÷ +85°C
 - execution with stainless steel housing manometers: -25°C ÷ +60°C
- humidity of ambient air < 95%
- allowable vibrations acc. To EN 60654-3: 2000; class VH6
 - 10...60Hz, amplitude < 0.35 mm
 - 60...500Hz, acceleration ≤ 5g
- working position: any

8. TRANSPORT GUIDELINES

The positioner together with equipment listed in the second chapter and the mounting kit with parts specified by the employer wrapped with a bubble wrap is placed in a cardboard box used as a unit package for the product. Free space inside the box is filled with bubble wrap, which protects the positioner against the movement inside it.

During the transport, the positioners in the above-mentioned package are placed in the bulk shipping box protecting against damages and weather conditions. Ambient temperature should not exceed -40 ÷ +85°C during transport.

The positioner in the shipping packaging (bulk shipping box) should be protected against direct impact of precipitation.

9. INSTRUCTIONS FOR UNPACKING AND STORAGE

The recipient should check the condition of shipping packaging after receiving the consignment. Then the devices in unit packages should be taken out, unpacked and visually inspected with respect to damages. Devices should be stored in unit packages in closed rooms. Air in storage place should not contain admixtures of aggressive vapors and gases.

10. ASSEMBLY MANUAL

10.1. General recommendations

Prior to installation of the positioner on actuator it is necessary to:

- keep positioners in open packaging until their temperature is equal to the room temperature, where they are to be installed.
- check whether the intended use of the positioner and enclosed mounting kit are suitable for the actuator on which it should be installed (see technical data sheet of mounting kit of the positioner and plate on the packaging of enclosed mounting kit).

10.2. Assembly of the positioner on actuator 37 and 38 manufactured by Polna S.A. – version APIS-A1X0-... with mounting kit APIS A0001-SS or SO type P1 and R1 manufactured by Polna S.A. – version APIS-1X0-... with mounting kit APIS-A0002-SS or SO

The positioner should be installed on actuator as follows:

- a) Remove the positioner from the packaging.
- b) Install the ball-and-socket joint on setting lever of the positioner in place corresponding to stroke of the actuator and tighten M5 nut (see Fig. 5 and 6)
- c) Place the coil spring lock washer and flat washer on two M8 screws (part of mounting parts).
- d) Screw in two screws, mentioned in the point c, to body of the actuator.
- e) Insert positioner's mounting bracket between actuator body and washers located on the M8 screws (bracket has a special recess for this purpose).
- f) Lightly tighten the positioner mounting bracket to actuator.
- g) Screw the clamping ring I and III to the actuator spindle using two M6 screws.
- h) Install the M8 nut and flat and coil spring lock washer on extension arm set.
- i) Screw extension arm set into clamping ring III; then adjust its length and move whole positioner in relation to the positioner using longitudinal cut-out for fixing screws in a mounting bracket to ensure that lever set (installed later) is parallel to actuator piston rod. If the extension arm is too long it should be cut to the required length (see Fig. 5 and 6).
- j) Install the M5 nut on spindle assembly.
- k) Screw in the lever set into connector of extension arm adjusting the length in such way that after setting the position of piston rod in half (50%) of the stroke set the setting lever is placed in a horizontal position. If the lever set is too long it should be cut to the required length.

The connection of lever set with extension arm's connector, extension arm with clamping ring III and mounting bracket with actuator body should be secured by tightening firmly all screws and nuts.

i

After coupling the string with extension arm, the movement of the stroke corresponding to full stroke of the actuator piston rod should be visually distributed in a symmetrical way with respect to the horizontal position of this lever.

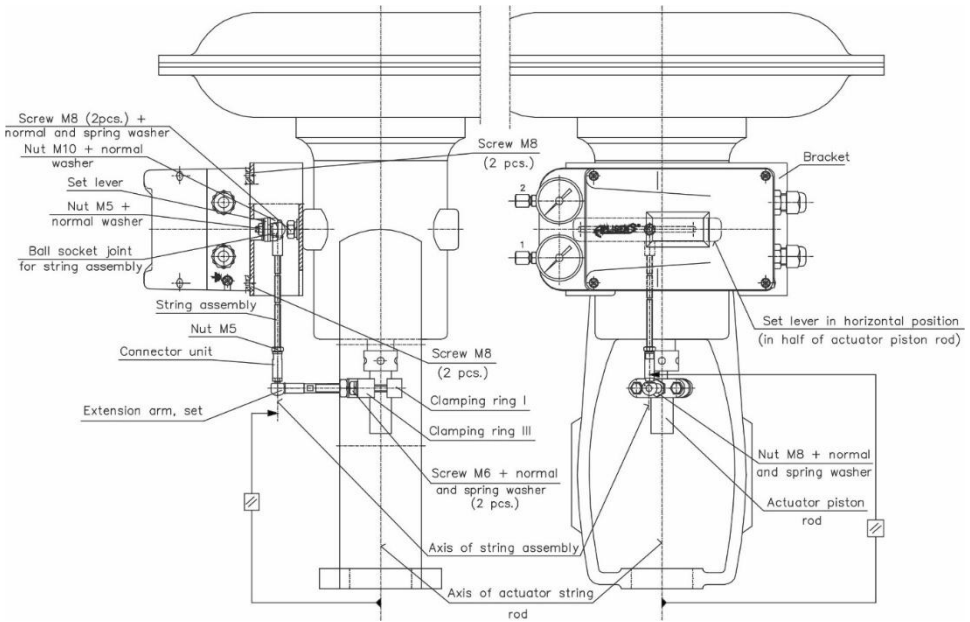

Fig. 5. Positioner APIS-1X0... with mounting kit APIS-A0001-SS or SO (positioner installed on yoke actuator type 37 or 38 manufactured by Polna S.A.).

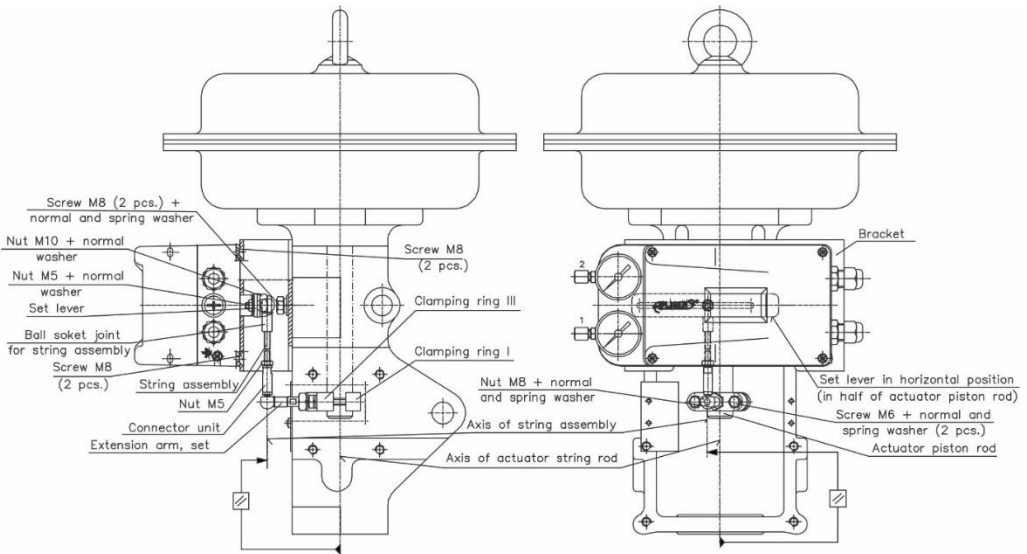

Fig. 6. Positioner APIS-1X0... with mounting kit APIS-A0002-SS or SO (positioner installed on multi-spring actuator type P1 or R1 manufactured by Polna S.A.).

10.3. Assembly of the positioner on actuator type P and R manufactured by Polna S.A. - version APIS-A1X0-... with mounting kit APIS-A0000-SS or SO

The positioner should be installed on actuator as follows:

- Take the positioner out of the packaging.
- Install the driver on setting lever of the positioner in place corresponding to stroke of the actuator and tighten the M5 nut (see Fig. 7)

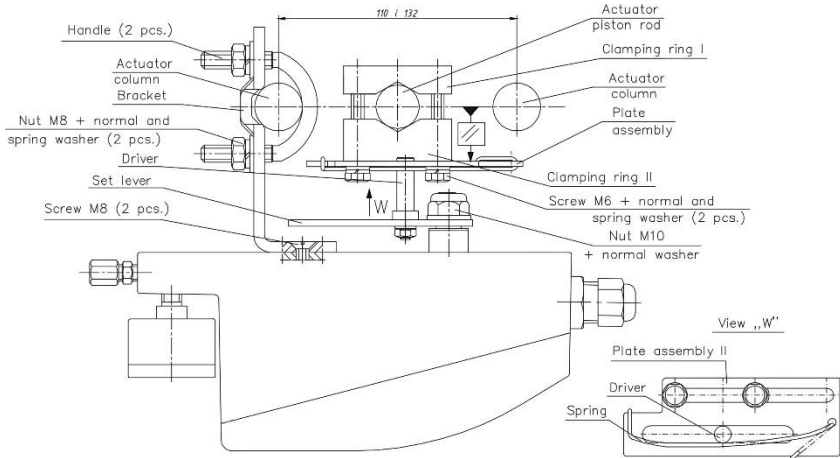

Fig. 7. Positioner APIS-1X0-... with mounting kit APIS-A0000-SS or SO (positioner installed on column cylinder type P or R with columns spacing 110 and 132 mm manufactured by Polna S.A.).

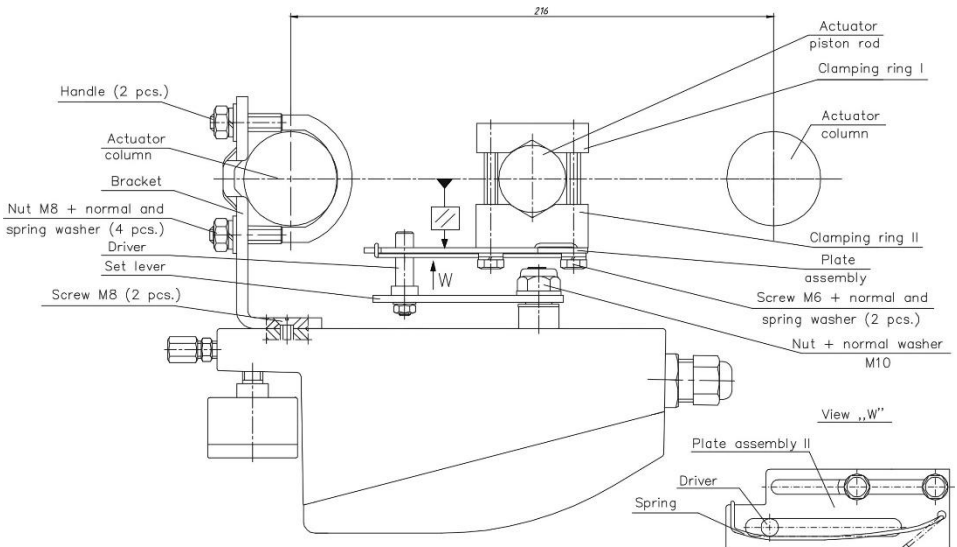

Fig. 8. Positioner APIS-1X0-... with mounting kit APIS-A0000-SS or SO (positioner installed on column cylinder type P or R with columns spacing 216 mm manufactured by Polna S.A.).

- c) Screw in clamping rings to actuator piston rod (clamping ring I and clamping ring II) with a plate using two M6 screws enclosed in the mounting parts



Plane of plate set should be parallel to a line connecting both axes of the column and actuator piston rod.

- d) Fix the positioner on columns using two handles - see Fig. 7 and 8, showing position of the mounting bracket taking into account the spacing of the axes of actuator columns.
 e) Connect driver with actuator piston rod by inserting it into proper cut out in a plate set - see View W in Fig. 8. The setting lever should take horizontal position (correct position of the positioner by shifting it on column of the actuator) in the 50% of stroke position.
 f) Tighten all nuts and screws firmly after the adjustment.



Driver should move smoothly in groove of the plate and without any stops. When the driver is coupled with a plate set movement of the lever corresponding to the full stroke of the actuator piston rod should be visually distributed in a symmetrical way with respect to horizontal position of this lever.

10.4. Assembly of the positioner on actuator with a control valve with a rib - compatible with PN-EN 60534-6-1:2001 e.g. on actuator manufactured by Samson or Arca Regler - version APIS-1X0... with a mounting kit APIS-A0003-SS or SO

The positioner should be installed on the actuator as follows:

- a) Remove the positioner from the packaging.
 b) Install the driver on the setting lever of the positioner in the place corresponding to stroke of the actuator and tighten the M5 nut (see Fig. 9)

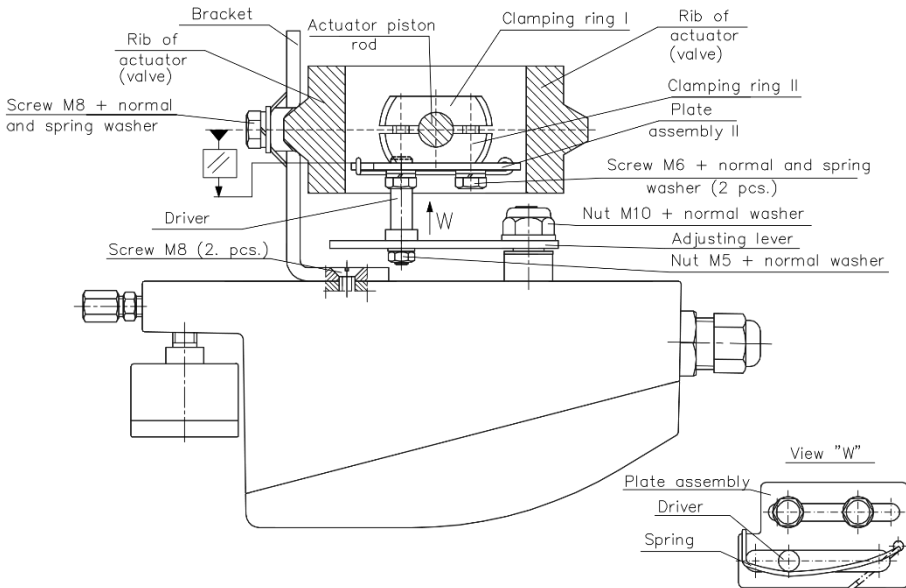

Fig. 9. Positioner APIS-1X0... with a mounting kit APIS-A0003-SS or SO (positioner installed on the actuator with control valve equipped with a rib - conforming EN 60534-6-1:2001 e.g. on actuator manufactured by Samson or Arca Regler)

- c) Screw in clamping rings to actuator piston rod (clamping ring I and clamping ring II) with a plate set II using two M6 screws enclosed in the mounting parts



The plane of the plate set II should be parallel to the line connecting both axes of ribs of the actuator (valve) and actuator piston rod.

- d) Connect the driver with actuator piston rod by inserting it into proper cut out in a plate set II - see View W in Fig. 9. Visually, in approximately half (50%) of stroke the setting lever should take horizontal position (correct position of the positioner by shifting it on rib of actuator matching the given opening in the actuator mounting bracket with threaded opening of actuator ribs).
- e) Tighten the positioner bracket firmly to rib of the actuator with M8 screw enclosed in the mounting parts.
- f) Tighten the other nuts and screws firmly.



Driver in groove of the plate II should move smoothly. When the driver is coupled with the set of plate II, the movement of the lever corresponding to the full stroke of the actuator piston rod should be visually distributed in a symmetrical way with respect to the horizontal position of this lever.

10.5. Assembly of the positioner on single or double operating actuator with rotational movement conforming EN ISO 5211, DIN 3337, VDI/VDE 38450 Namur e.g. on actuator manufactured by AIR TORQUE, EBRO ARMATUREN, EL-O-MATIC - version APIS-1X0-... and APIS-2X0-... with a mounting kit APIS-A0050-SS or SO

The positioner should be installed on the actuator as follows:

- a) Remove the positioner from the packaging.
- b) Install the coupling connector on the positioner shaft by tightening it lightly with two M5 screws. Pay attention to support both fixing screws on flat bevel on positioner shaft - see Fig. 10.
- c) Install the frame to the positioner body and tighten it firmly with four M6 screws - see Fig. 11.
- d) Depending on the actuator size you should set the correct height of the bracket by correct shifting of both parts on openings. Install four M6 screws and tighten it firmly with nuts after the adjustment.
- e) Check the direction of actuator shaft movement and position of screws on the coupling connector - Fig. 10.
- f) Install both brackets in this position using four M5 screws.
- g) Inspect visually whether the axis of the coupling connector matches the actuator axis and whether the bevel in the bottom part of the connector is located in cut out of the actuator shaft.
Correct the mutual position of the actuator relative to the positioner using a clearance on openings for M5 screws in angle sections.
- h) Tighten four M5 screws fixing brackets on the actuator.
- i) Move coupling connector closer to the actuator shaft and then lock it on the positioner shaft tightening two M5 screws firmly.



It is recommended to screw in two M5 screws on the coupling connector with thread locking compound e.g.: Loctite 222 or 243.

- j) Remove the clearance between frame and bracket by moving both parts towards each other. This operation should ensure the maintenance of visual parallelism of the frame tightened to the positioner in relation to a plane of the positioner from side of its shaft - see Fig. 11.
- k) Tighten firmly four M5 nuts locking the brackets with respect to the frame.

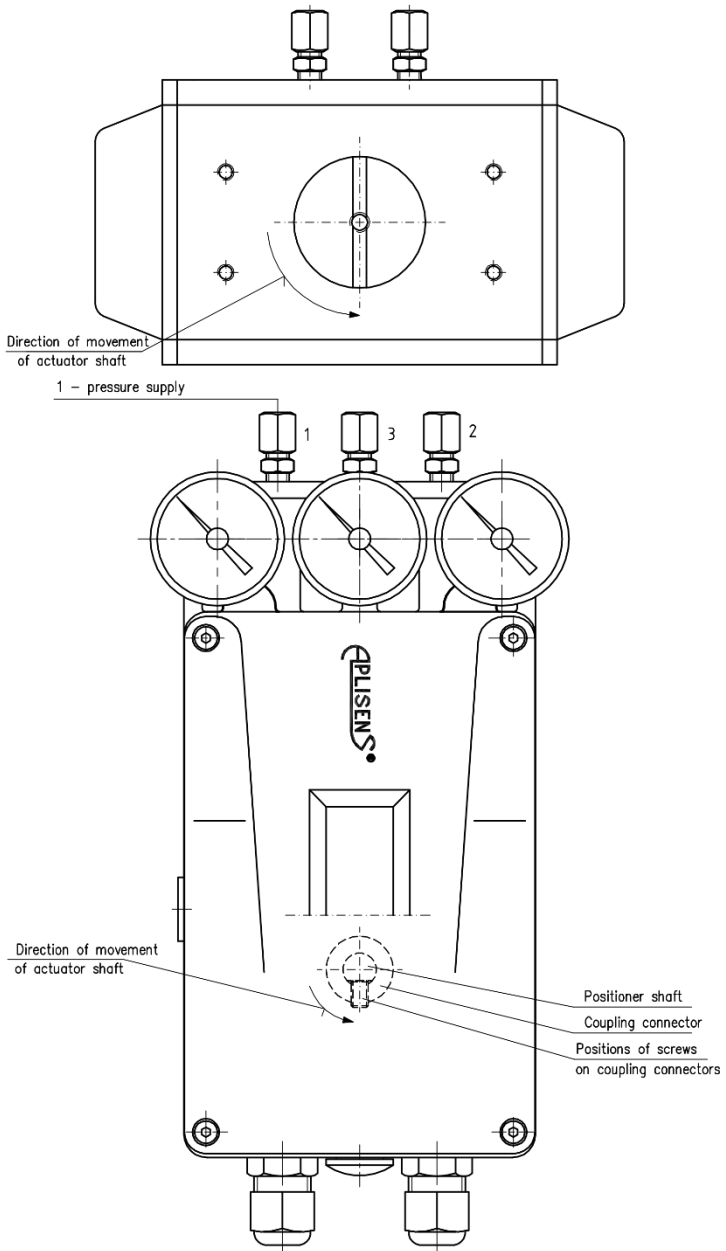

Fig. 10. Mounting position of the APIS-1X0... and APIS-2X0... positioner with respect to single-acting or double-acting actuator with rotational movement.

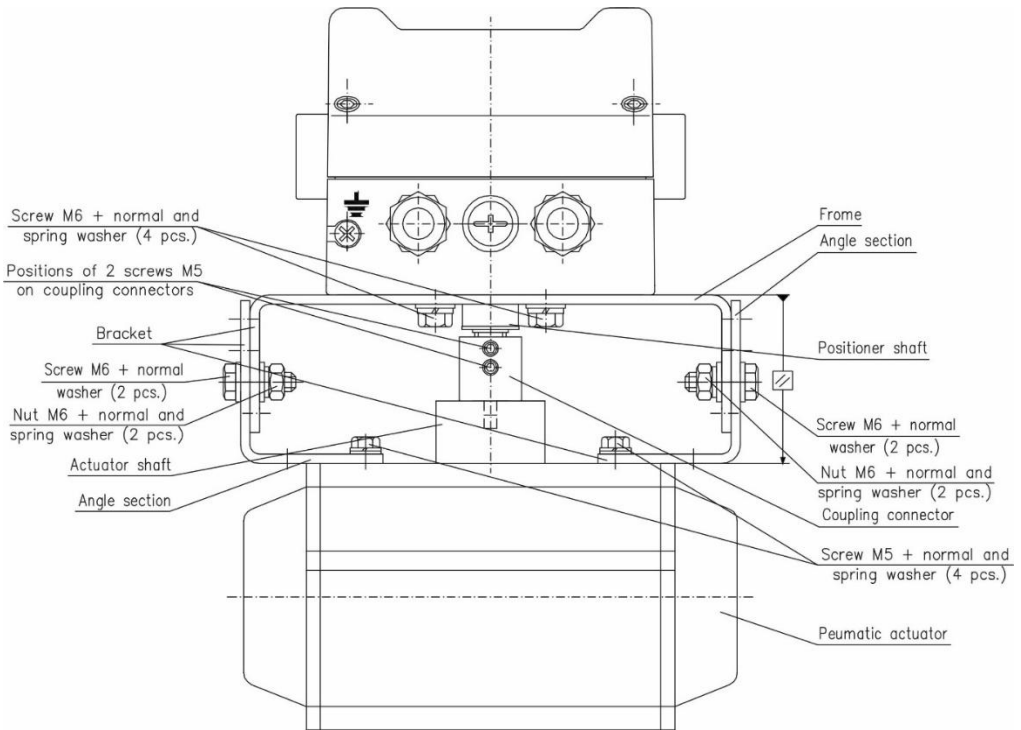

Fig. 11. Assembly of the APIS-1X0-... and APIS-2X0-... positioner with mounting kit APIS-A0050-SS or SO on single-acting and double-acting actuator with rotational movement.

10.6. Assembly of the positioner with double action actuator with linear movement CNOMO or conforming the ISO 6431 e.g. actuator manufactured by PREMA Kielce, FESTO - version APIS-2X1-..., APIS-2X2-... with a mounting kit APIS-AXXXX-SS or SO

The positioner should be installed on the actuator as follows:

- Install the clamp rings I and III on the piston rod with the extension arm by tightening two M6 screws as shown in Fig. 12.
- Install two mounting brackets fixing the position transducer on the actuator.
- Install a tip with ball-and-socket joint to the position encoder. Tighten firmly a jam nut on tip with mobile threaded spindle of the encoder.
- Connect the extension arm with a ball-and-socket joint installed on the position transducer.
Adjust the extension arm length to ensure that after the installation of the position transducer on actuator it will be possible to install a plate as shown in Fig. 12.



If the extension arm is too long it should be cut to the required length.

- Tighten the M8 nut on extension arm.
- Install position transducer using two mounting clamping rings to ensure that when the actuator piston rod is inserted its mobile spindle protrudes at least 3÷6 mm from its initial position.

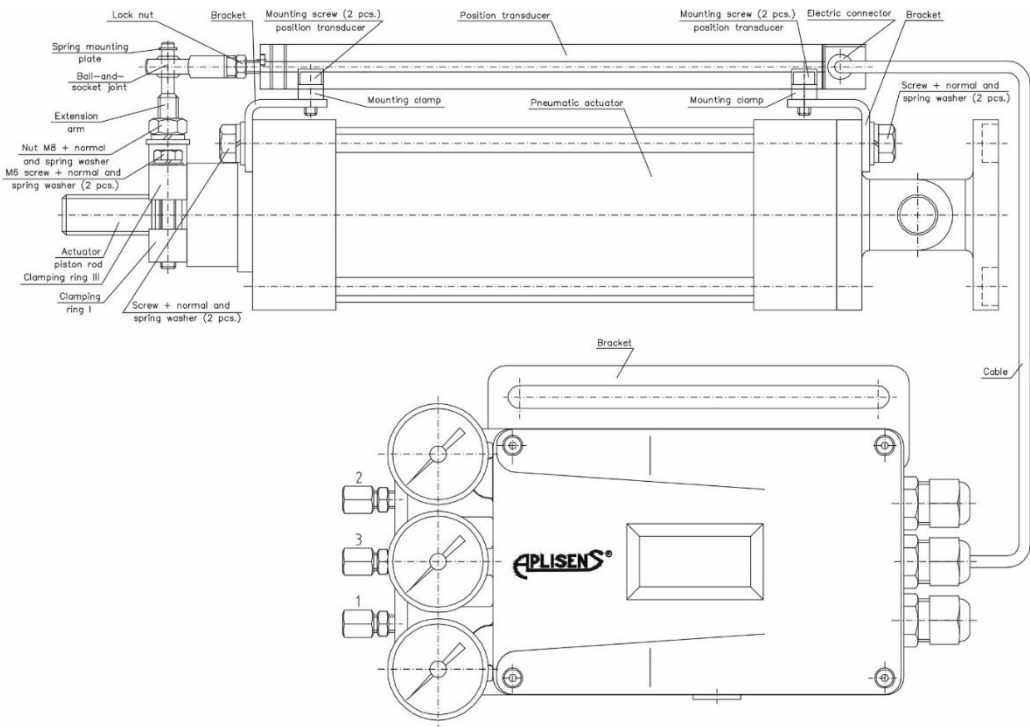

Fig. 12. Assembly of the APIS-2X1-..., APIS-2X2-... positioner with mounting kit APIS-XXXX SS or SO (positioner mounted externally of the double-action linear actuator e.g: CNOMO series or conforming with ISO 6431 (PREMA KIELCE or FESTO)).

Check whether maximum advance of the actuator piston rod will not cause damage of the position transducer.



Make a correction of length of mobile spindle of the transducer by screwing/undoing a tip with a ball-and-socket joint from this arm and/or moving the transducer in relation to its mounting clamping rings. After these operations, the counternut on the tip with mobile spindle of transducer and bolts fixing the transducer with clamping rings to brackets should be re-tightened.

- g) Install the spring plate on the extension arm.
- h) Install positioner e.g.: on the wall or other selected position, using a bracket and two M8 screws enclosed to the mounting kit.



Distance of the positioner from actuator is limited by length of the electrical cable connecting the positioner with position encoder

- i) Connect connector of electrical cable connected to a terminal strip of the positioner with socket of position transducer (tighten a nut located on electrical interface).
- j) Tighten firmly all screws, bolts and nuts.

10.7. Assembly of the positioner with double acting linear actuator
e.g. CNOMO series or conforming with ISO 6431 (PREMA
KIELCE or FESTO) – version APIS-2X0-.... with a mounting kit
APIS-AXXX-SS or SO

a)

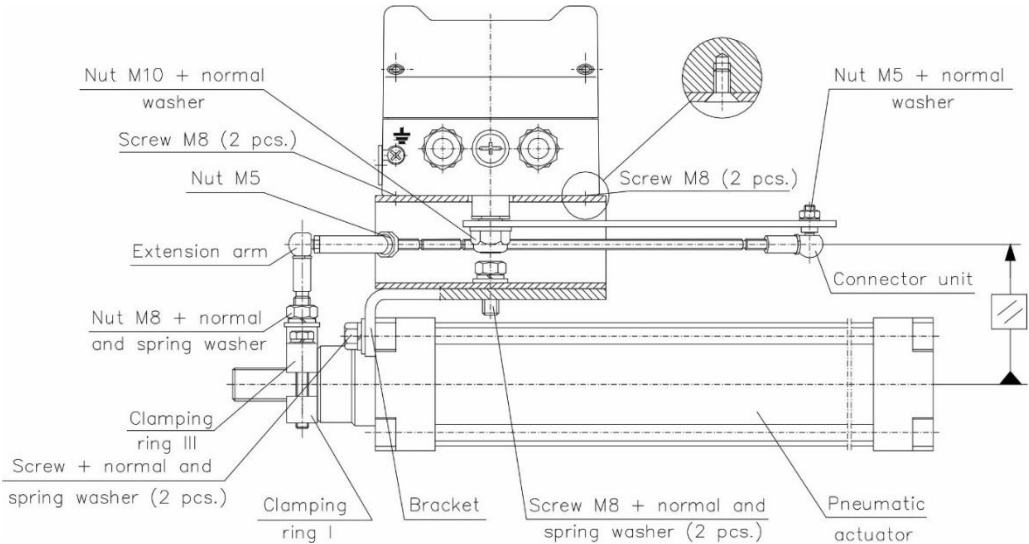
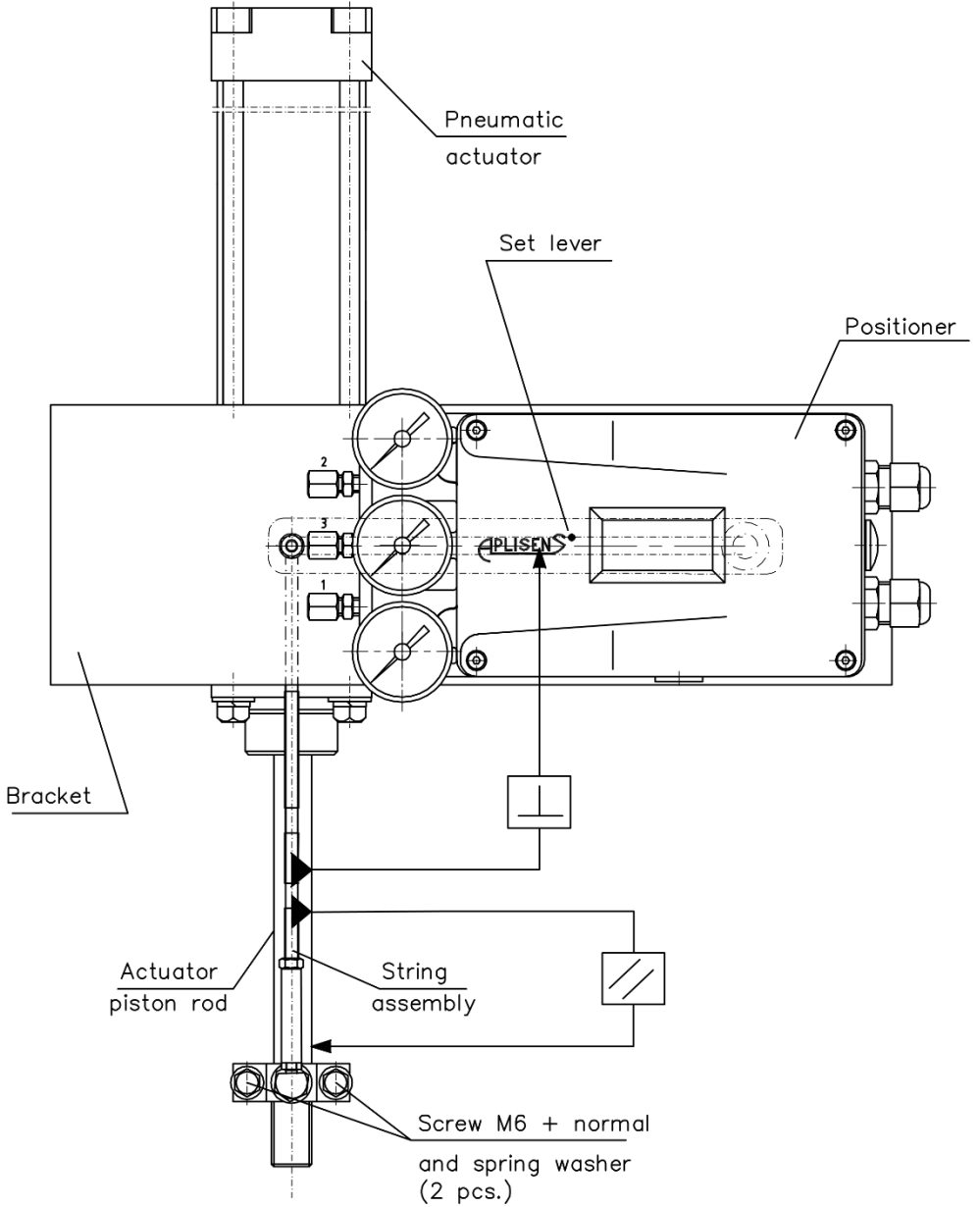

Fig. 13 Assembly of the APIS-2X0-... with mounting kit APIS-XXXX-SS or SO

- a) Unpack the positioner
- b) Install the adjusting lever on the rotary axis and tight it with a nut.
- c) Install the bracket to the positioner using 4 M8 screws.
- d) Install the string assembly on the set lever corresponding to the stroke of the actuator.
- e) Install the bracket and tight it to the actuator using two screws.
- f) Tight lightly the positioner on the actuator using the bracket from point e.
- g) Tight the clamping ring I and III with extension arm to the actuator piston rod. Then adjust the length of the extension arm so that after connect to the connector unit was parallel as seen on Fig 13.
- h) Connect the string assembly with the set lever in 50% of actuators stroke. The set lever must be set perpendicularly to the actuator piston rod.

b)



10.8. Rules of installation of pneumatic hoses

The pneumatic hoses to supply pressure reducer should be as short as possible. The installed hoses should not be exposed to mechanical loads.

Avoid bends during laying. Hoses should be blown with the air before connecting them in order to dry them and to remove the contaminations. It is recommended to use annealed copper pipe \varnothing 6x1 or \varnothing 8x1.

Supply pressure should be led to pneumatic connector marked with "1", while cables of output signals marked with "2" or "3" should be connected with the given chambers of the actuator.



Pneumatic connectors denoted by P3 and P6 codes do not provide IP65 ingress protection in case of depressurized pneumatic pipes.

11. USER'S MANUAL

Setting of parameters and configuration of the positioner can be carried out as follows:

- using the positioner keyboard - this method is discussed in details in section 11.2.3.
- using a computer with the *Raport 2* software equipped with proper help tab.

11.1. General information

11.1.1. Control buttons

Three control buttons (Fig. 14) are used for:

- Δ - increasing the displayed parameter value, switching to the previous function, confirmation of the selected function;
- ∇ - the decreasing the displayed parameter value, switching to the following function,
- \leftarrow - confirmation of the selected parameter or function.

The buttons Δ and ∇ have assigned typematic (auto - repeat) function during programming of values of the parameters. This function allows stepwise increase Δ or decrease ∇ of the value of the parameter when the given button is held for more than 0.6 s. Auto-repeat function acts of 10 times per second.

Positioner menu is presented in the Fig. 15. Buttons Δ and ∇ are used to select the given menu item.

Execution of the given function requires additional confirmation by Enter (\leftarrow) button.

The parameter is automatically saved and next menu item will be indicated after the setting. The choice of parameter setting sequence is arbitrary.

Parameters setting can be carried out or repeated any time of operation of the positioner.

The parameters set are saved in the positioner, nonvolatile memory.

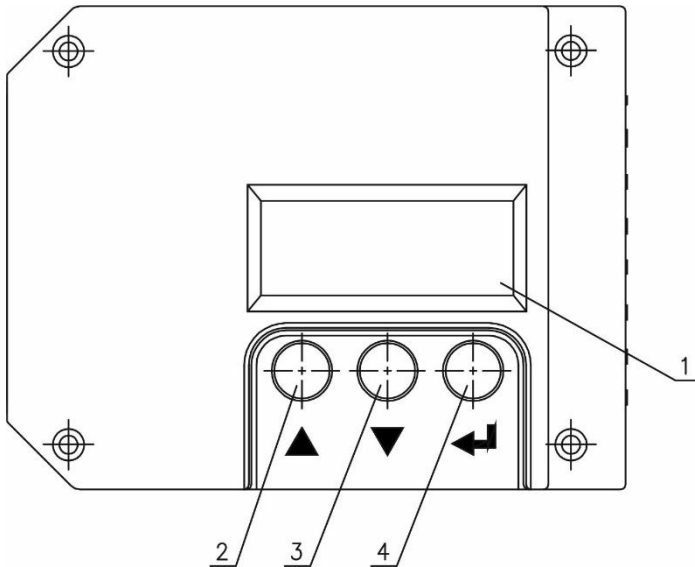

Fig. 14. Keyboard of the APIS positioner.

1. LCD display, alphanumerical;
2. Pushbutton Δ ;
3. Pushbutton ∇ ;
4. Pushbutton \leftarrow ;

11.1.2. Positioner servicing levels

Communication of the user with microprocessor positioner APIS is carried out at three service levels (Fig. 15):

- I service level - normal operation mode
- II service level - transient mode
- III service level – configuration and parameters settings mode

The information on: displacement value **PV** of piston rod, input (control) signal (current) **SP**, internal temperature of the positioner **T °C**, correct position indicator **CP IND**, manual actuator control mode **MANUAL** (option) and software version **VER En X.XX** are displayed on the display in the first service level.



Actual internal temperature of the positioner is displayed periodically (each 30s for 2s period) in the left corner of the display (applies only for **SP** and **PV**).

Change of the item presented on the positioner display is sequential by successive pressing the button ∇ (Fig.15) in the following order: **PV**, **SP**, **T °C**, **CP IND**, **MANUAL**, **VER En X.XX**, or button Δ in reverse order.

The switch from the normal operation mode to the transient mode is arbitrary and takes place after pressing both buttons Δ and ∇ at the same time. **PIN** – password for advanced software and configuration functions of the positioner will appear on the display. (III service level).

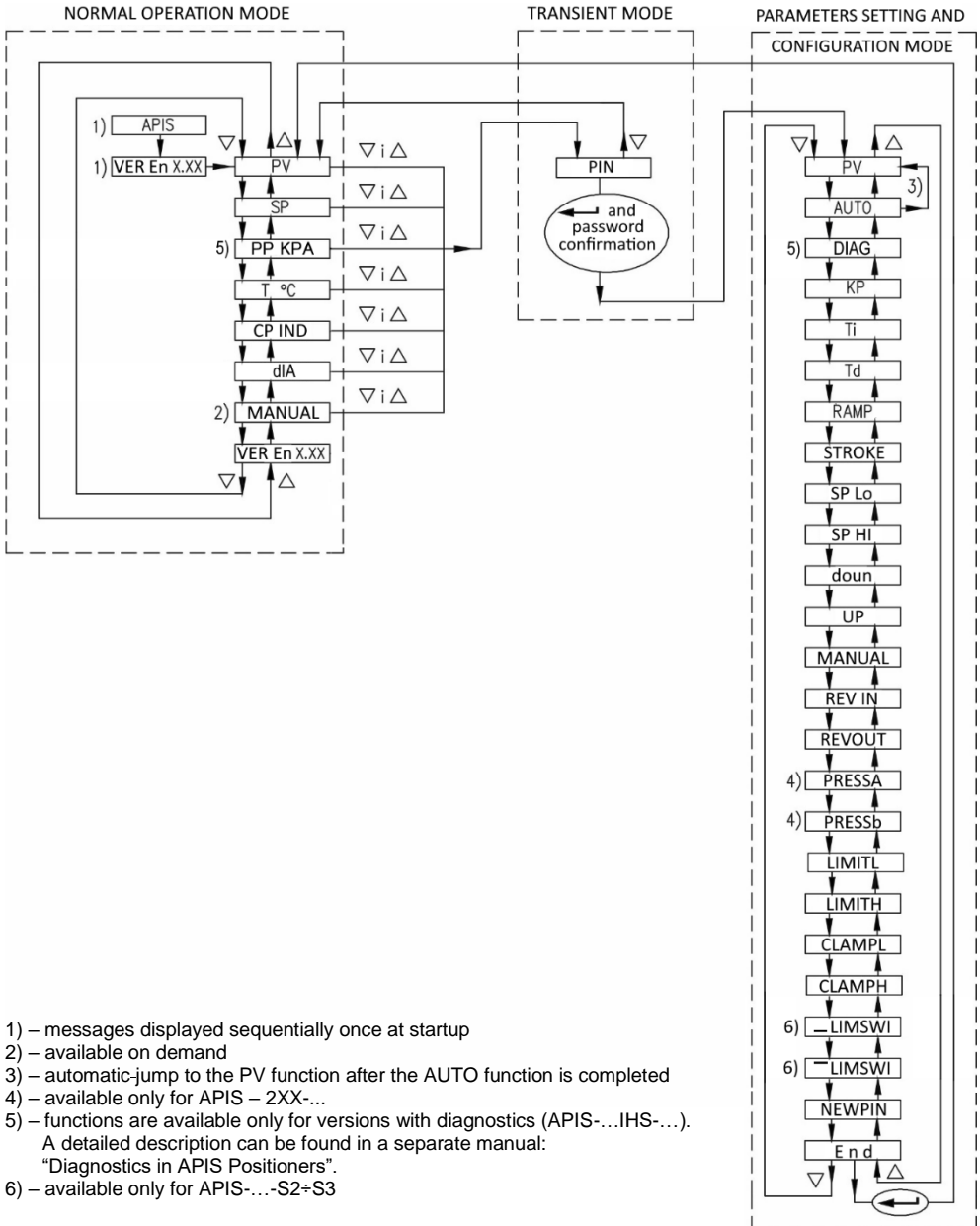

- 1) – messages displayed sequentially once at startup
 2) – available on demand
 3) – automatic-jump to the PV function after the AUTO function is completed
 4) – available only for APIS – 2XX-...
 5) – functions are available only for versions with diagnostics (APIS-...IHS-...).
 A detailed description can be found in a separate manual:
 “Diagnostics in APIS Positioners”.
 6) – available only for APIS-...-S2+S3

Fig. 15. Menu of the APIS positioner functions

Switching to the third service level - the last one, that is setting the parameters and configuration, is allowed only for authorized persons that is after entering the password during confirmation of **PIN** function using button.

11.2. Positioner functions

Launch the positioner acc. to section 11.3. before starting operation.

11.2.1. I (1st) service level - normal operation mode



During the normal operation mode, it is possible to read the value of displacement of the actuator piston rod, the input control signal's value, the internal positioner temperature, checking the correct setting of the position transducer and software version.

11.2.1.1. PV – readout of actual value of displacement of actuator piston rod

The following will appear on display, e.g.:

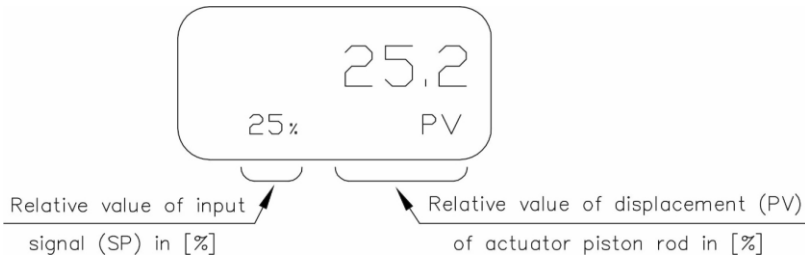

This information indicates that the positioner is at the I (1st) service level (normal operation mode).

11.2.1.2. SP – readout of actual value of input (control) signal (current)

- Using the button Δ or ∇ move to **SP** symbol, e.g.:

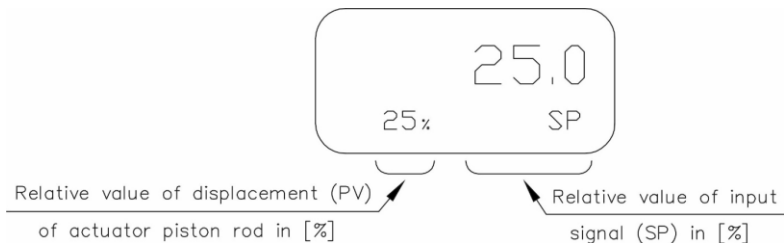

Pressing the button Δ once results in return to **PV** display mode as in the section (11.2.1.1.).

11.2.1.3. $T^{\circ}C$ - readout of actual internal temperature of the positioner

- Set the $T^{\circ}C$ symbol using buttons Δ or ∇ :

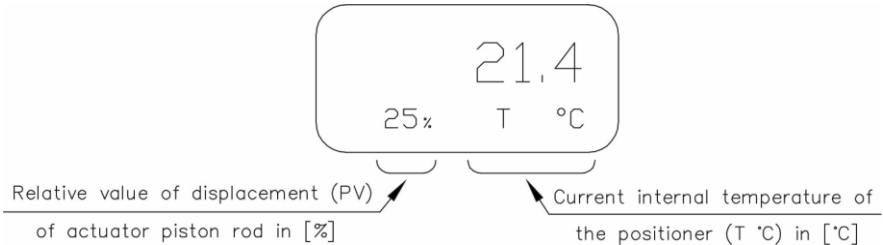

Pressing the button Δ once results in return to **SP** display mode as in section (11.2.1.2.), while successive pressing of this button results in return to **PV** display mode as in the section (11.2.1.1.).

11.2.1.4. **CP IND** – Correct position indicator (encoder)

- Set the **CP IND** symbol using buttons Δ or ∇ :

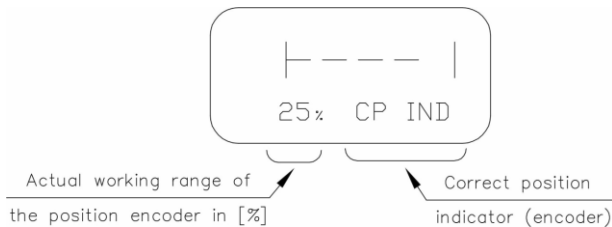

Pressing the button Δ once results in return to $T^{\circ}C$ display mode as in section (11.2.1.3.), while successive pressing of this button results in return to **SP** and **PV**.

11.2.1.5. **MANUAL** – manual control mode for the actuator - function available on demand

- Using buttons Δ or ∇ move to **MANUAL**:

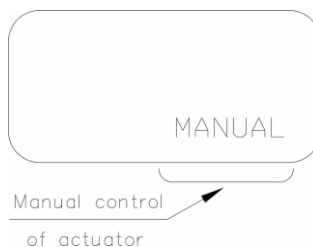

- Press the button \leftarrow ; the following will appear on the display, e.g.:

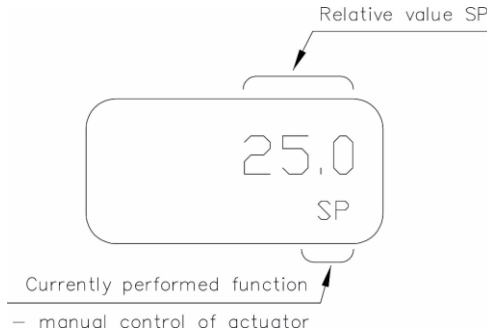

- Change the position of the actuator piston rod by pressing or holding the button Δ or ∇ .

The actuator piston rod stops moving when the button Δ or ∇ is released. When position specified by the operator is reached – the actuator piston rod remains there until the operator executes another command. Adjustment functions of the positioner are active during the implementation of the **MANUAL** command



- Press the button \leftarrow ; the following will appear on display:

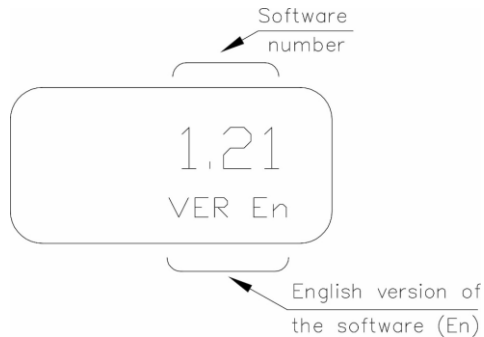

After completing the **MANUAL** command, the positioner returns to automatic control mode driven by external control signal **SP**.



Pressing the button Δ once results in the return to **CP_IND** display mode (11.2.1.4), while subsequent pressing of this button results in return to **T °C, SP, PV**.

11.2.1.6. VER En X.XX – information on software version of the positioner

- o Set the **VER En X.XX** symbol using buttons Δ or ∇ :

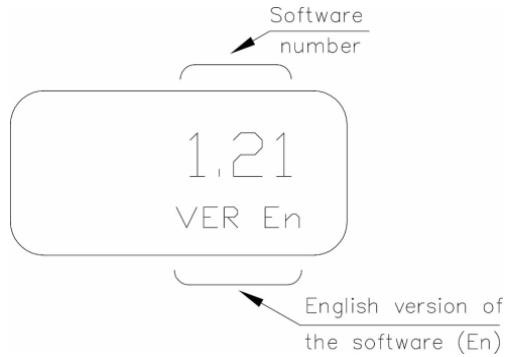

VER En 1.21 indicates version for single acting actuators (APIS**1**XX-...), with software no. **21**.
or

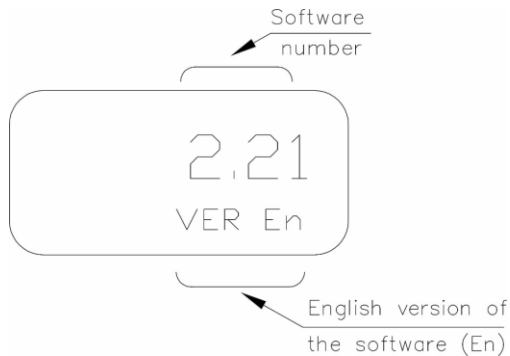

VER En 2.21 indicates a version for double-acting actuators (APIS-**2**XX-...), with software no. **21**.
or

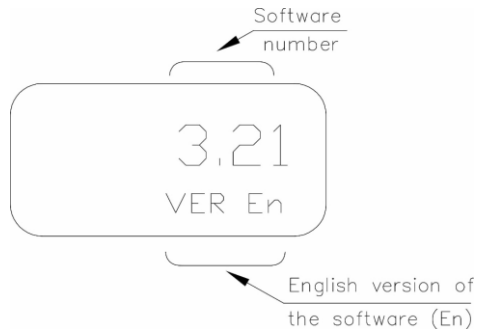

VER En 3.21 indicates a software in the Manual mode operation is shifted to first operating level. It applies to the single-acting actuators (APIS-**1**XX-...), with software no. **21**.

or

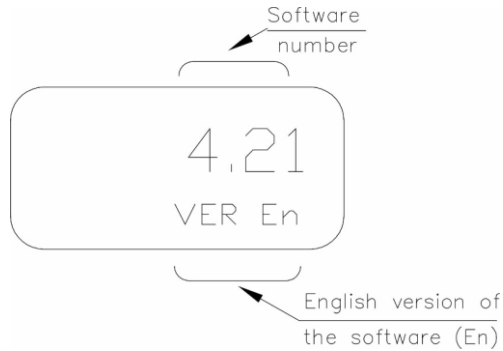

VER En 4.21 indicates a software in which the Manual mode operation is shifted to the first operating level. It applies to the double-acting actuators (APIS-**2**XX-...), with software no. **21**.

If the user does not intend to change the language from **EN** (English) to **PL** (Polish), the

i

button Δ or ∇ should be pressed once. Pressing the Δ button will bring you back to the **MANUAL** (11.2.1.5.) mode, and subsequent press of this button will return you to **CP IND**, **T °C**, **SP**, **PV** modes. Pressing the button ∇ will switch to the display state of the current value of displacement of the actuator piston rod; the following may appear on display, e.g.:

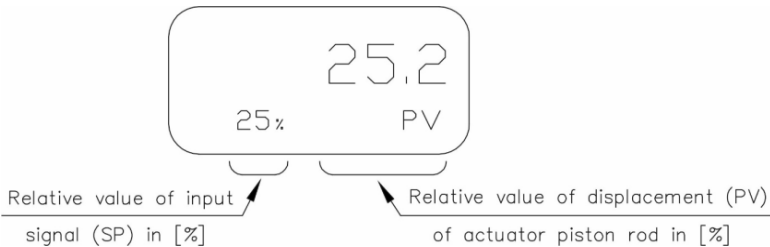

- If the user intends to change the language from **EN** (English) to **PL** (Polish), the button **←** should be pressed; the following will appear on display:

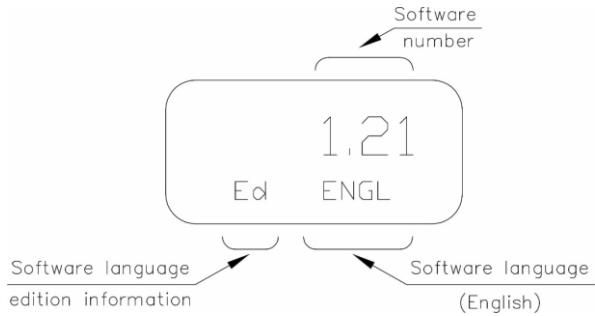

- Press button **Δ** or button **∇** once; the following will appear on display:

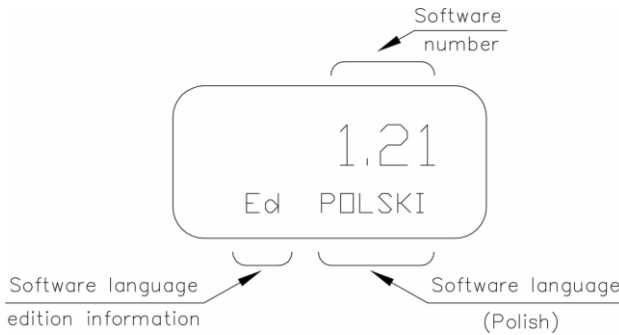

- Press the button **←** ; the following will appear on display:

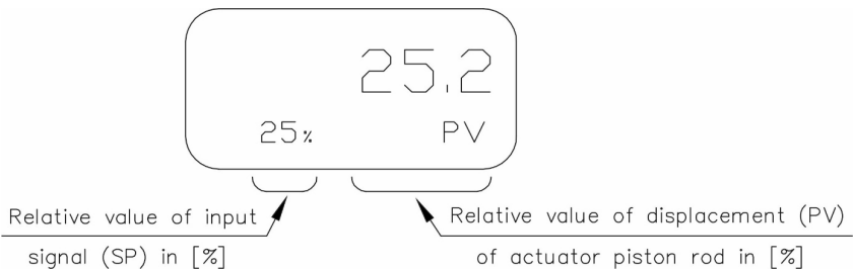

11.2.2. II (2nd) service level - transient mode

11.2.2.1. PIN – Access password for advanced software and configuration functions of the positioner

With the display as in sections 11.2.1.1. or 11.2.1.2. or 11.2.1.3. 11.2.1.4. or 11.2.1.5 or 11.2.1.6, to pass from the first to the second service level, i.e., to the transient mode, simultaneously press the two buttons Δ and ∇ . The display will show:

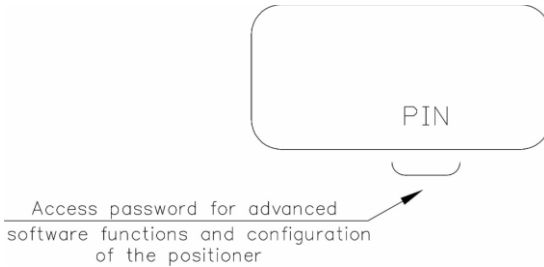

Such information indicates that the second service level (transient mode) has been reached.

Moving in the menu in the area of the second level:

- pressing the button Δ once results in the return to the normal operation mode and displaying condition as in section 11.2.1.1.,
- to switch from the second service level to the third one that is to parameters setting and configuration mode:
 - o Press button \leftarrow ; the following will appear on display:

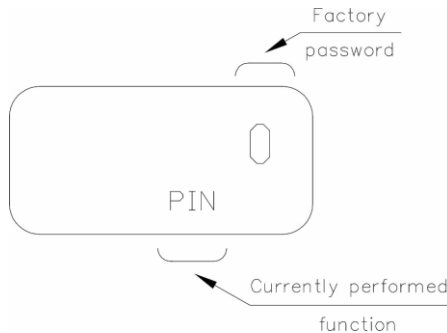

If factory password has been already changed then it should be set using buttons Δ and ∇ .

Confirm the password with a button ↵; the following will appear on display:

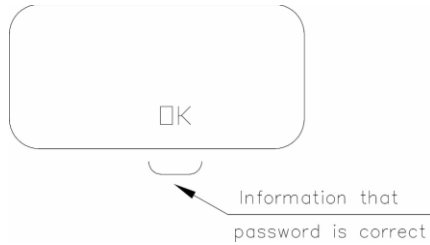

Information on the approval of the password will disappear from the positioner display. Then the following will be displayed e.g.:

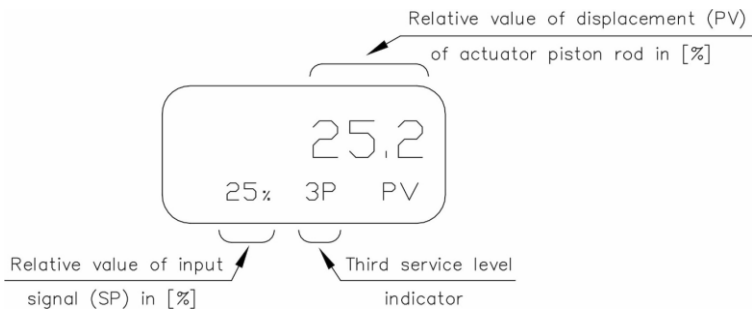

If the entered password is incorrect, then the device will not switch to the third level, and the following will appear on-display, e.g.:

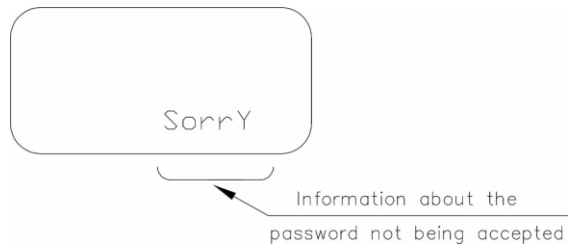

e.g.:

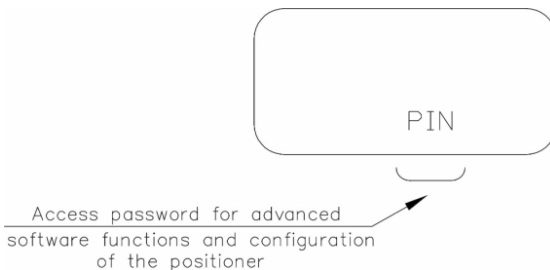

Then the user should re-enter the password carrying out the operations mentioned above. The number of incorrect password entries is unlimited.



Change of the password is possible exclusively in the third service level by means of function **NEW PIN**. Please refer to the procedure described in section 11.2.3.23. Users should push Δ and ∇ buttons for this purpose.

11.2.3. III (3rd) service level – configuration and parameters settings mode

11.2.3.1. PV – readout of actual value of displacement of actuator piston rod

The following will appear on the display after entering the correct password as in sect. 11.2.2.1:

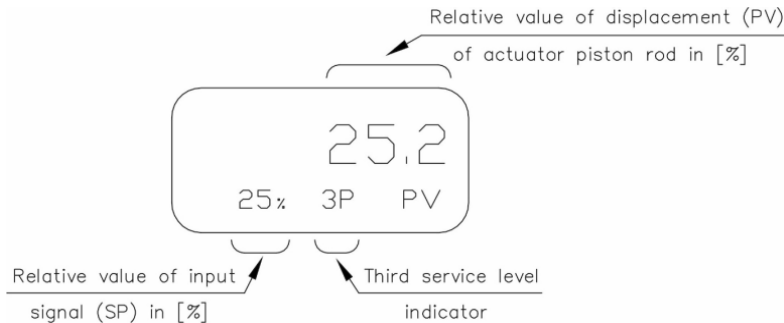

This function is used to preview the value of piston rod displacement during parameters settings and configuration process at the third service level.

11.2.3.2. AUTO – automatic tuning of positioner settings

- o Set the **AUTO** function using buttons Δ or ∇ :

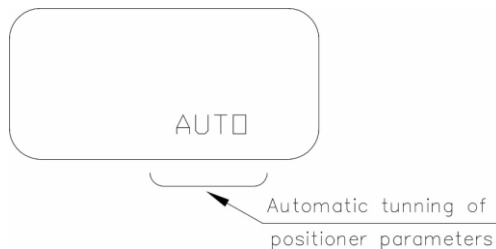

- Press the button \leftarrow ; the following will appear on-display:

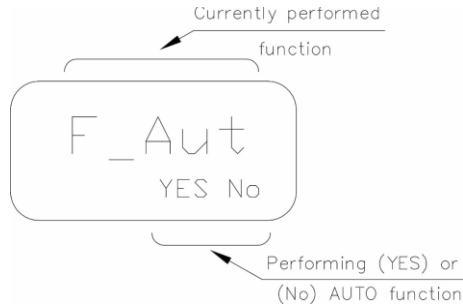

- If the function of the positioner's automatic tuning is not to be performed (No), press the button; the next function will appear on display, i.e., **KP** - see section 11.2.3.3.
- If the function of the positioner's automatic tuning is to be performed (**YES**), press the button Δ .

Automatic tuning procedure for positioner will start.



Because of several movements (in/out) of the actuator piston rod during performing of the **AUTO** function, the user should be particularly careful.



Selection of control pressures for actuator chambers (**PRESS. A** and **PRESS. b**) applies only to **APIS-2XX-....**

Duration of the function **AUTO** depends on volume of actuator chambers and changes from 30 sec. to several minutes.

Ending of the automatic tuning algorithm of parameters of the positioner is signaled by the text on the display:

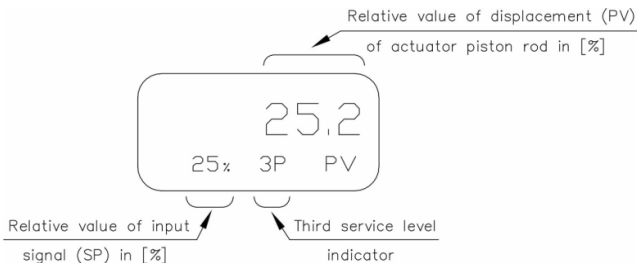

The above information indicates that we are on the third service level.



If by auto-tuning the positioner, the message **Sorry** appears, it means that the function **AUTO** was not correctly executed. The reasons for this are described in section 13 LP.9.



If the **AUTO** positioner auto-tuning function has to be omitted, press the button ∇ ; the following menu function appears on display, i.e. **KP** – see section 11.2.3.3.

11.2.3.3. KP – gain k_p of the PID controller

- Set the **KP** symbol using the Δ or ∇ buttons, e.g.:

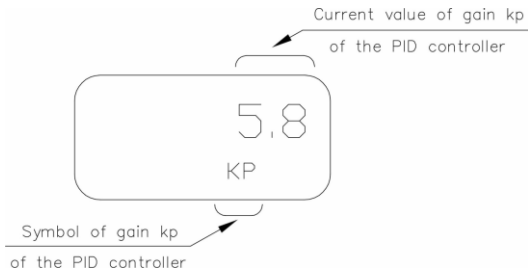

- Press the button \leftarrow ; the following will appear on display, e.g.:

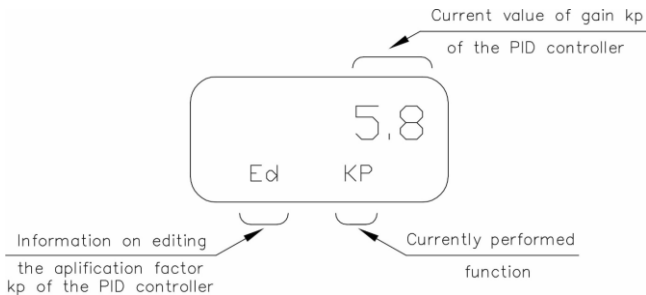

- The user should change the value of gain coefficient by pressing and/or holding the button Δ , or ∇



Gain k_p has a severe impact on the positioner's stability. It is determined automatically by calling the **AUTO** function – see section 11.2.3.2.

- Confirm the set value **k_p** with the button \leftarrow ; the following will appear on display e.g.:

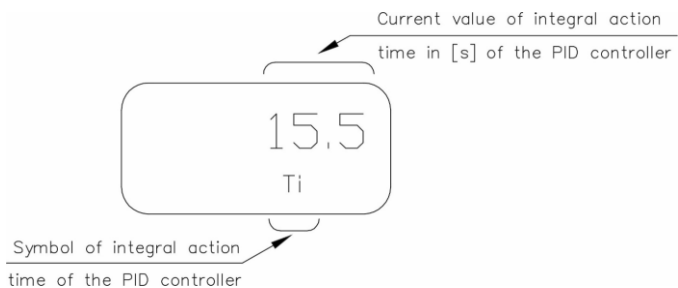

11.2.3.4. T_i – integral action time of the PID controller

- Set the T_i symbol using Δ or ∇ buttons, e.g.:

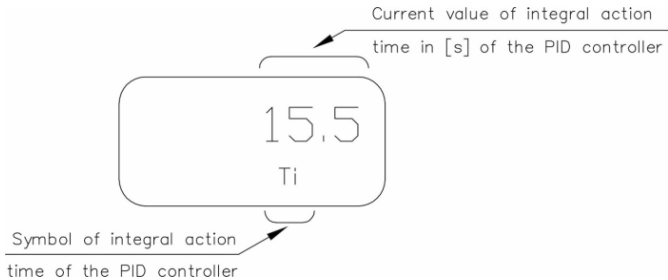

- Press the button \leftarrow ; the following will appear on display, e.g.:

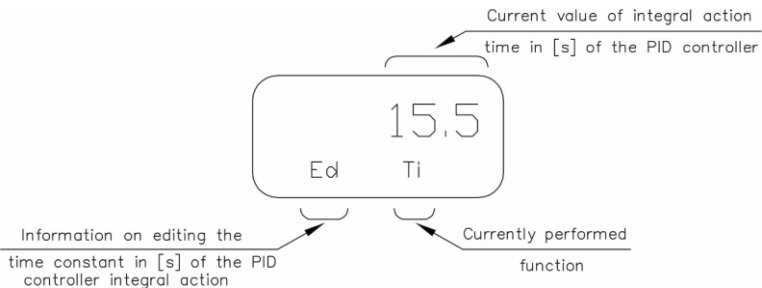

- The user should change the value of integral action time by pressing and/or holding the button Δ , or ∇ .
- Confirm the set value T_i using the button \leftarrow ; the following will appear on display, e.g.:

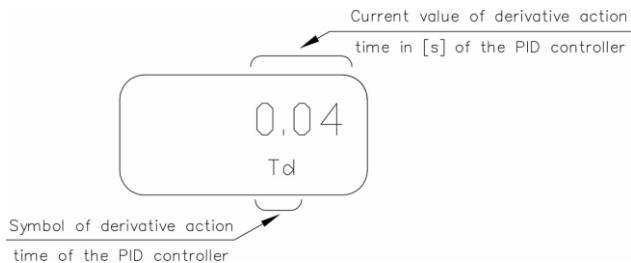

Integral action time T_i is determined automatically by calling the **AUTO** function – see sect. 11.2.3.2.

11.2.3.5. T_d – derivative action time of the PID controller

- Set the T_d symbol using Δ or ∇ buttons e.g.:

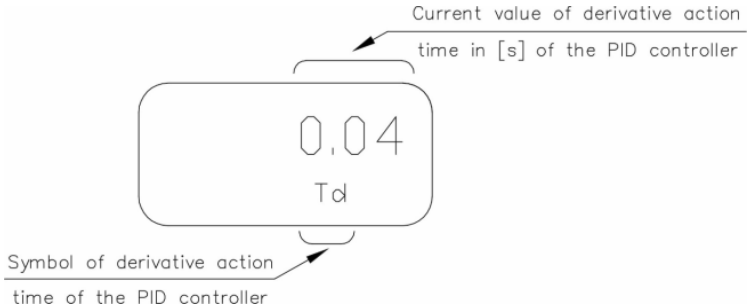

- Press the button \leftarrow ; the following will appear on display, e.g.:

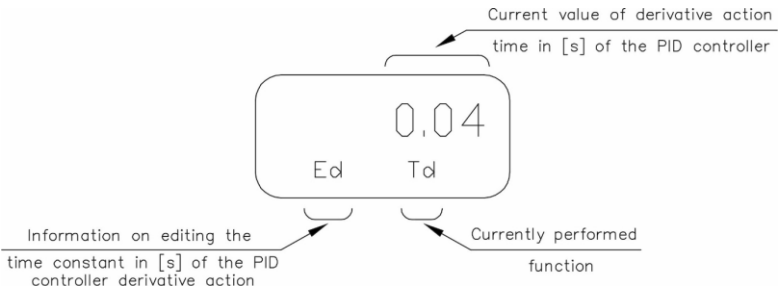

- The user should change the value of derivative action time of the controller by pressing and/or holding the button Δ , or ∇ .
- Confirm the set value T_d with button \leftarrow ; the following will appear on display, e.g.:

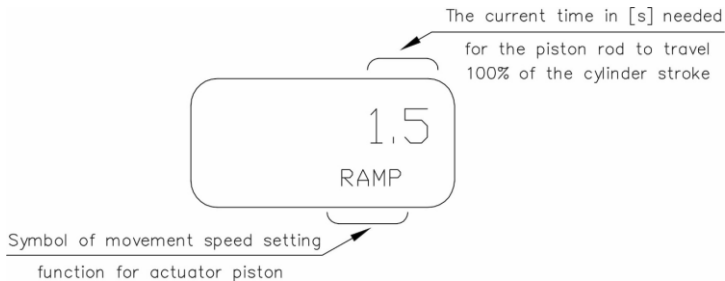

Derivative action time T_d is determined automatically by calling the **AUTO** function – see section 11.2.3.2.

11.2.3.6. RAMP – speed of actuator piston rod

- o Set the **RAMP** command using Δ or ∇ buttons, e.g.:

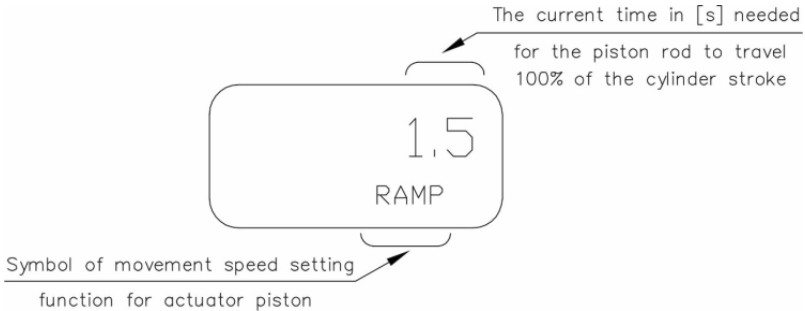

- o Press the button \leftarrow ; the following will appear on display, e.g.:

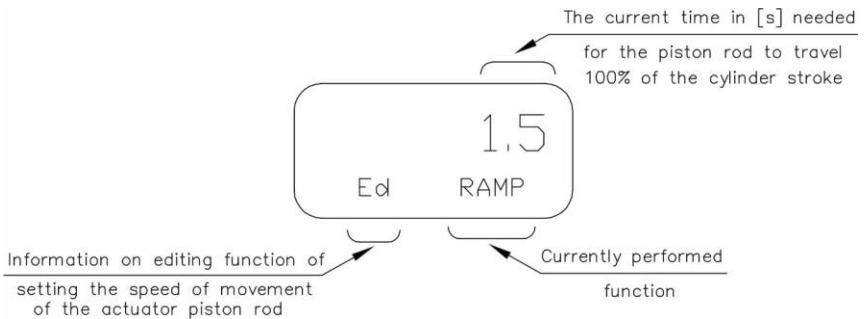

- o The user should set the required value of the **RAMP** coefficient by pressing and/or holding the button Δ or ∇ .
- o Confirm the set value **RAMP** using the button \leftarrow ; the following will appear on display:

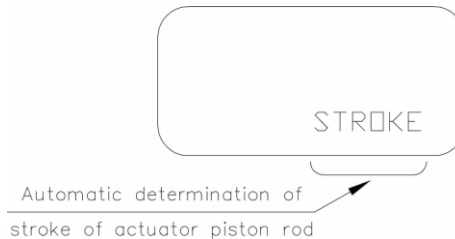

Speed of actuator piston rod **RAMP** is determined automatically by calling the **AUTO** function – see section 11.2.3.2.

11.2.3.7. STROKE – automatic determination of stroke of piston rod of the actuator

- o Set the **STROKE** function using buttons Δ or ∇ :

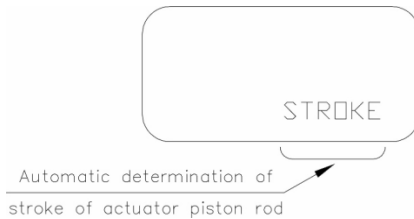

- o Press the button \leftarrow ; the following will appear on display:

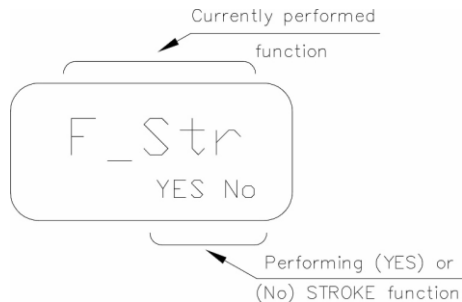

- o If the function of automatic determination of stroke is not intended to be performed (**No**), press the button \leftarrow ; the next function will appear on display, i.e., **SP Lo** - see section 11.2.3.8.
- o If the function of automatic determination of stroke is to be performed (**YES**), press the button Δ ; the following will appear on the display e.g.:

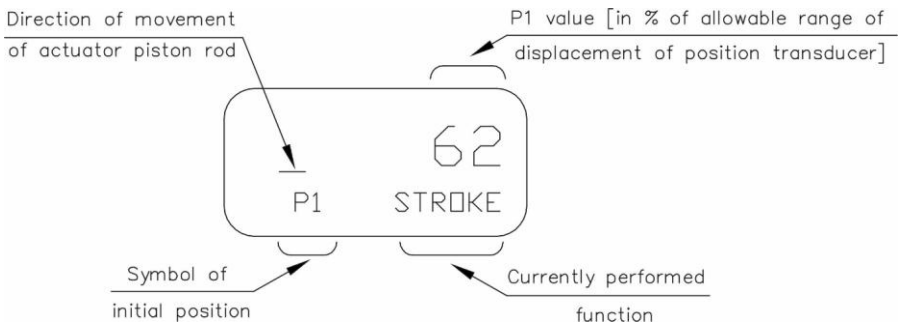

Then determination of the range of movement of piston rod of the actuator in automatic mode will start. This process lasts from several to several dozens of seconds.



The actuator piston rod extends or retracts by this operation. The following will appear on display, e.g.:

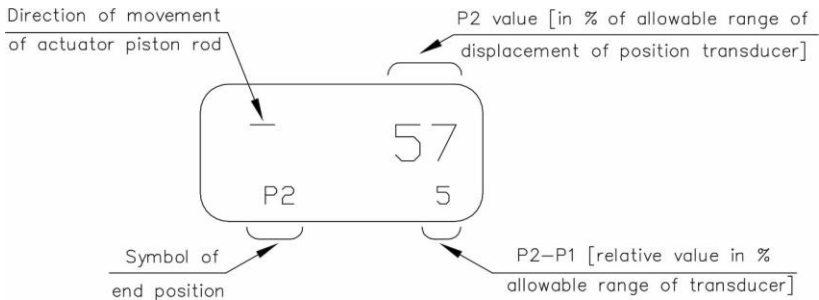

The following text will be displayed on the positioner display when the actuator piston rod's automatic determination of movement stroke is completed.

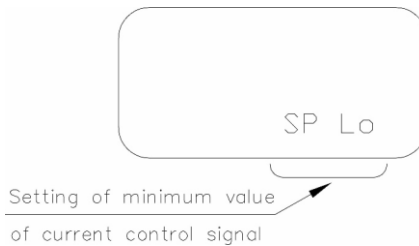

If during of automatic determination of stroke the message **Sorry** appears, it means that the function **STROKE** was not correctly executed. The reasons for this are described in section 13 LP.9.



When the function of automatically determining the range of movement of the **STROKE** actuator piston rod has to be omitted, press ∇ button; the next function will appear, i.e. **SP Lo** – see section 11.2.3.8.



The range of actuator piston rod is determined automatically by calling the **AUTO** function – see sect. 11.2.3.2.

11.2.3.8. SP Lo – setting of minimum value of current control signal

- Set the **SP Lo** function using buttons Δ or ∇ :

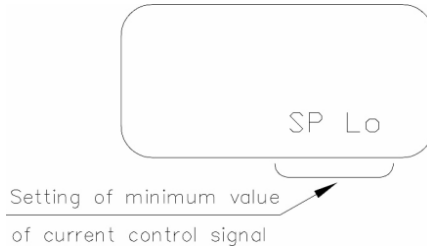

- Press the button \leftarrow ; the following will appear on display, e.g.:

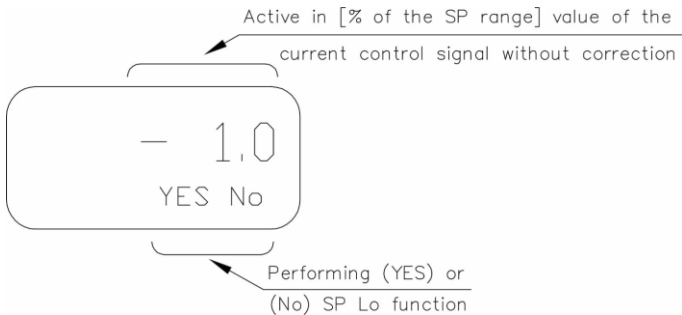

- If the minimum current signal's setting is not to be performed (**No**), press the button \leftarrow ; the next menu function will appear on display, i.e., **SP HI** - see section 11.2.3.9.
- If the minimum current signal's setting is to be performed (**YES**) please adjust the required minimum current using the current source attached to terminals 1 and 2 (see Fig. 17) (typically 4,000 mA DC), and then press the Δ button. On the display of the positioner will appear following:

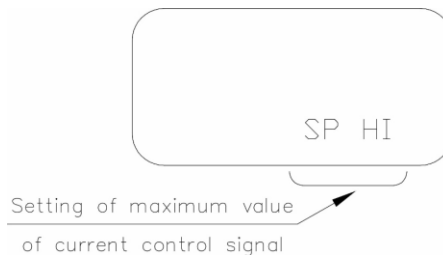

The positioners are delivered with set minimum current control signal value of 4,000 mA DC.

11.2.3.9. SP HI – setting the maximum value of current control signal

- Set the **SP HI** function using buttons Δ or ∇ :

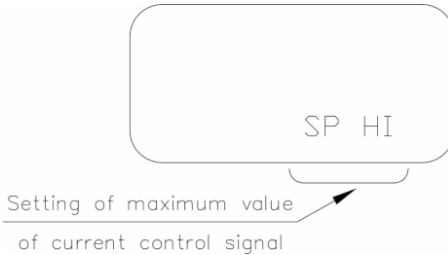

- Press the button \leftarrow ; the following will appear on display, e.g.:

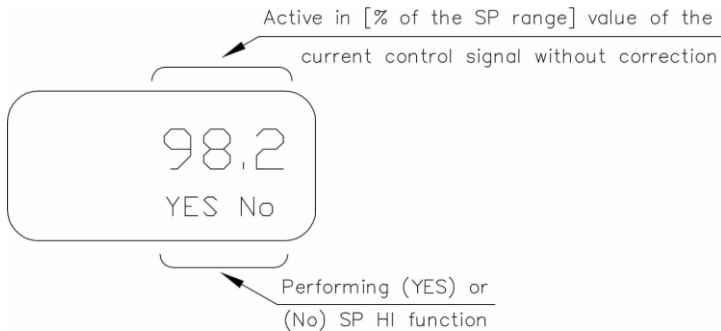

- If the maximum current signal's setting is not to be performed (**No**), press the button \leftarrow ; the next menu function will appear on display, i.e., **doun** - see section 11.2.3.10.
- If the maximum current signal's setting is to be performed (**YES**) please adjust the required maximum current using the current source attached to terminals 1 and 2 (see Fig. 17) (typically 20,000 mA DC), and then press the Δ button. On the display of the positioner will appear following:

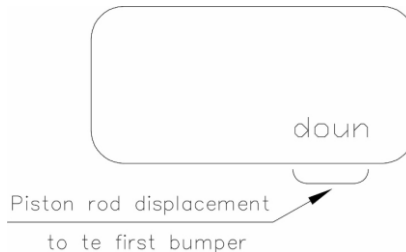

The positioners are delivered with set maximum current control signal value of 20,000 mA DC.

11.2.3.10. DOWN – displacement of actuator piston rod to the first bumper

- o Set the **doun** function using buttons Δ or ∇ :

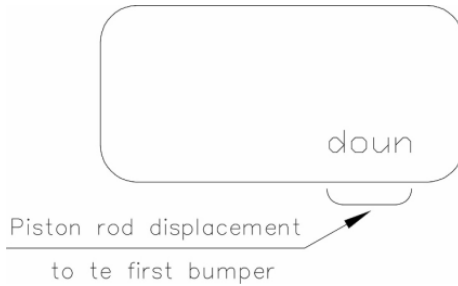

- o Press the button \leftarrow ; the following will appear on display:

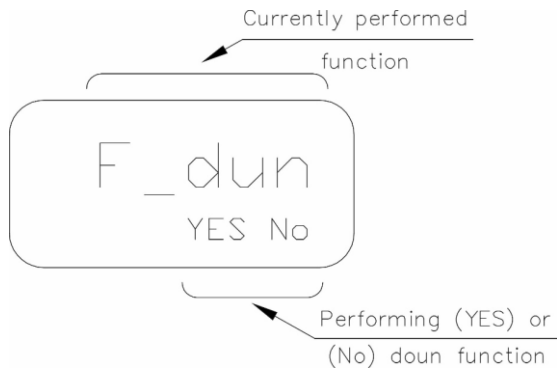

- o If the function of displacement of actuator piston rod to the first bumper is not to be performed (**No**), press the button \rightarrow ; the following function will appear on display, i.e., **UP** - see section 11.2.3.11.
- o If the function of displacement of actuator piston rod to the first bumper is to be performed (**YES**), press the button Δ ; on the display of the positioner will appear following:

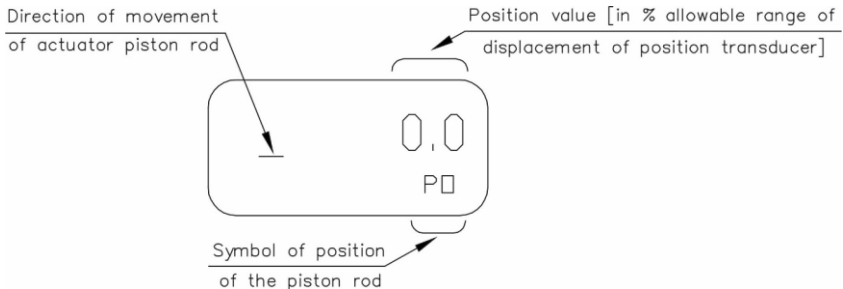



doun command results in unloading of chamber of the pneumatic actuator and causes the movement of the piston rod to the first bumper which is called conventionally as **doun**. When this position is reached – the actuator piston rod remains there until the operator executes other command.

- Press the button \leftarrow ; the following will appear on display:

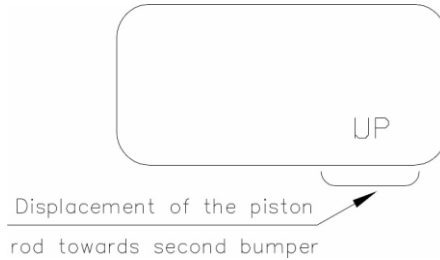

Ending of **doun** command results in restarting of the positioner in on-line control mode, that is in normal automatic operation mode of the actuator.

11.2.3.11. UP – displacement of the actuator piston rod to the second bumper

- Set the **UP** function using buttons Δ or ∇ :
-

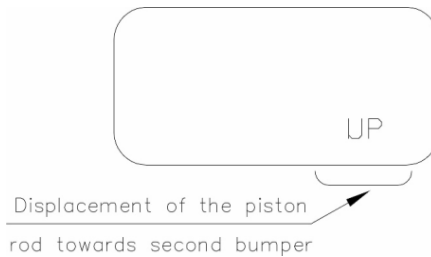

- Press the button \leftarrow ; the following will appear on display:

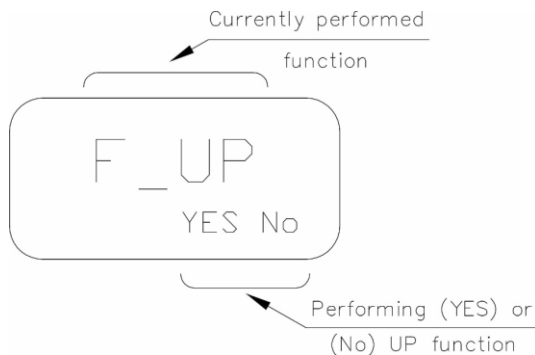

- If the function of displacement of actuator piston rod to the second bumper is not to be performed (**No**), press the button ↵ ; the following function will appear on the display, i.e. **MANUAL** - see section 11.2.3.12.
- If the of displacement of actuator piston rod to the second bumper is to be performed (**YES**), press the button Δ ; on the display of the positioner will appear following:

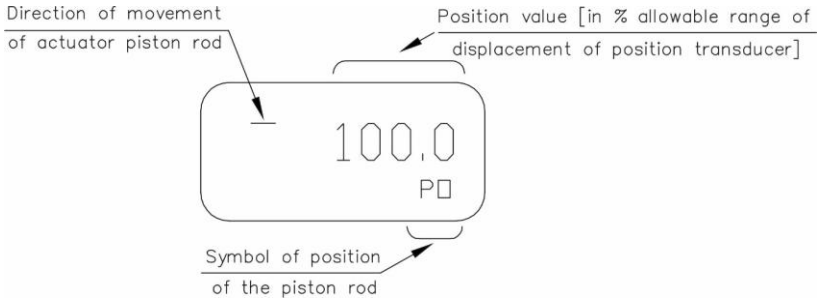

i

UP command results in loading the chamber of the pneumatic actuator and causes the movement of the piston rod to the second bumper position called conventionally as **UP**. When this position is reached – the actuator piston rod remains there until the operator executes other command.

- Press the button ↵ ; the following will appear on display:

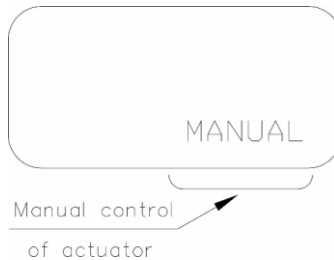

i

Ending of **UP** command results in restarting the positioner in on-line control mode, that is in normal operation mode of the positioner.

11.2.3.12. MANUAL – manual control mode for the actuator

- o Set the **MANUAL** function using buttons Δ or ∇ :

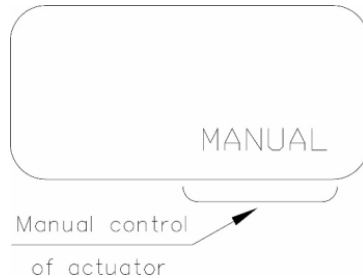

- o Press the button \leftarrow ; the following will appear on display, e.g.:

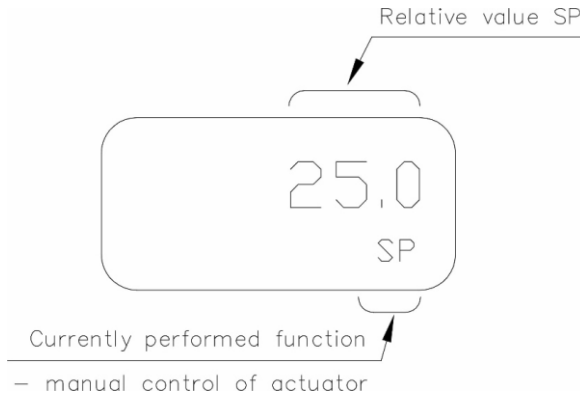

- o Change the position of the actuator piston rod by pressing or holding the button Δ or ∇ .



The actuator piston rod stops moving when the button Δ or ∇ is released. When position specified by the operator is reached – the actuator piston rod remains there until the operator executes another command. Adjustment functions of the positioner are active during the implementation of the **MANUAL** command.

- Press the button \leftarrow ; the following will appear on display, e.g. :

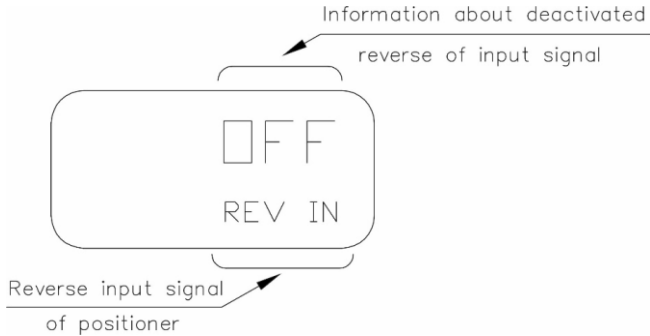

Ending the **MANUAL** command results in the return to control in the automatic operation mode with the external control signal **SP**.

11.2.3.13. REV IN – reverse of the input signal

- Set the **REV IN** function using Δ or ∇ buttons, e.g.:

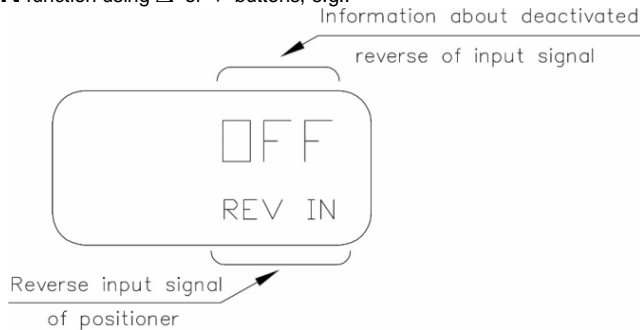

- Press the button \leftarrow ; the following will appear on display:

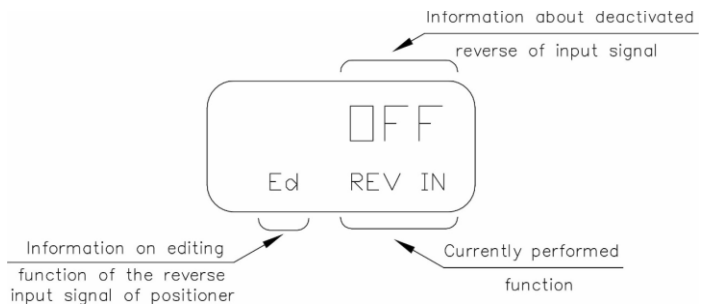

- If the user does not intend to activate the reverse of the input signal, then he/she should press the button \leftarrow ; the next function will appear on display, i.e., **REVOUT** - see section 11.2.3.14

- If the user intends to activate the reverse of the input signal, then he/she should press the button ∇ or Δ once; then the following will appear on display:

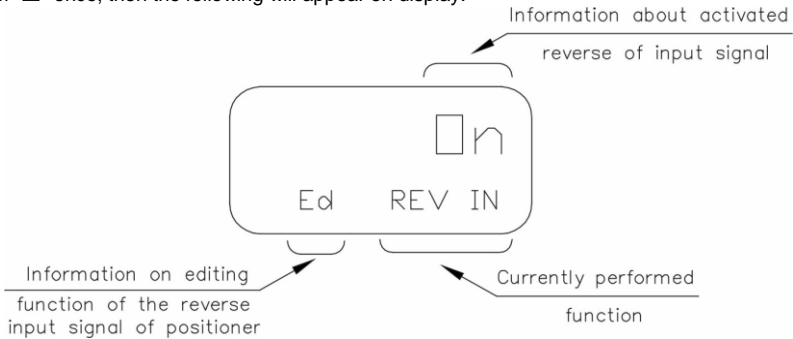

- Confirm the activation of the reverse of the input signal with the button \leftarrow ; then the following will appear on display, e.g.:

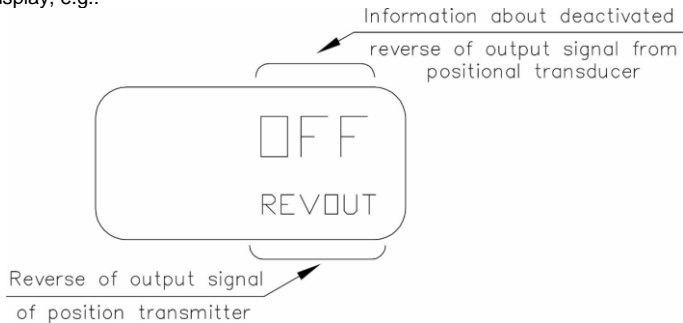

By default (factory) function of reverse of input signal is deactivated (**OFF**).

11.2.3.14. REV OUT – reverse of the output signal from the position transmitter

- Set the **REVOUT** function using Δ or ∇ buttons, e.g.:

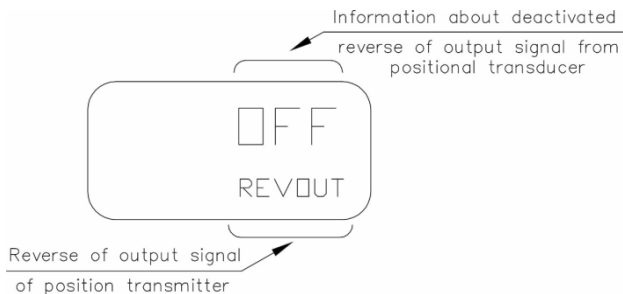

- Press the button \leftarrow ; the following will appear on display:

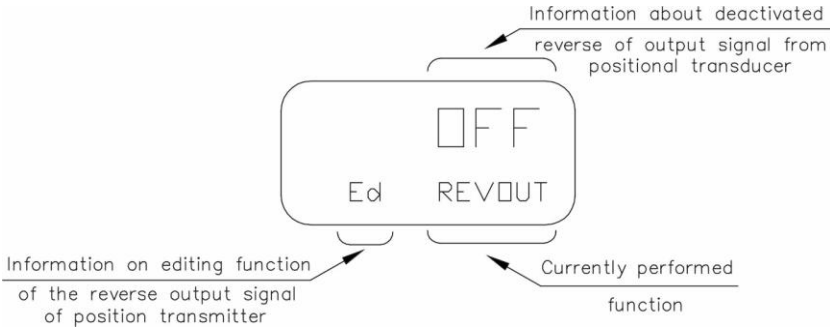

- If the user does not intend to activate the reverse of the output signal from the position transmitter, then he/she should press the button \leftarrow ; the following function will appear on display, i.e.:
 - for executions APIS-1XX-..., **LIMIT L** - see section 11.2.3.17
 - for executions APIS-2XX-..., **PRESSA** - see section 11.2.3.15
- If the user intends to activate the reverse of the output signal from the position transmitter then he/she should press the button ∇ or Δ once; then the following will appear on display:

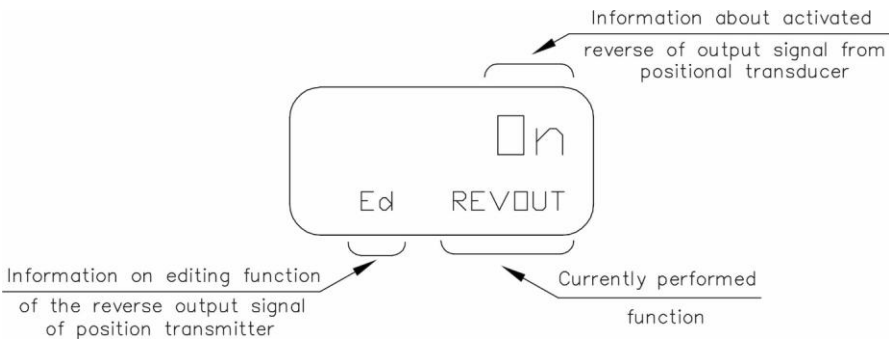

- Confirm the activation of the reverse of the output signal from the position transmitter with the button \leftarrow ; then the following will appear on display, e.g.:

- for executions APIS-1XX-...:

The bottom of the position of the actuator piston rod

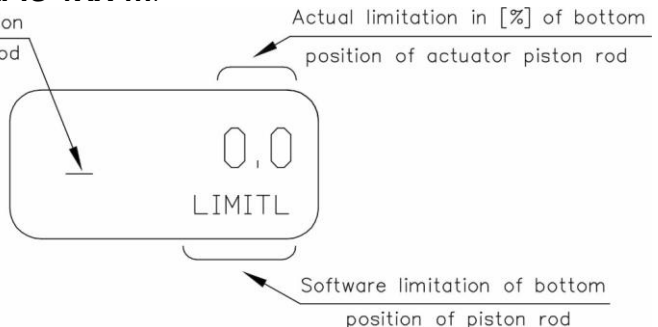

- for executions APIS-2XX-...

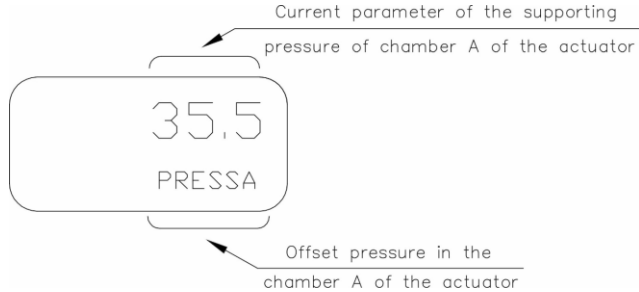

i The function of the reverse of the output signal from position transmitter is factory deactivated (**OFF**) for both versions.

11.2.3.15. PRESSA – offset pressure of chamber A of the actuator (chamber connected with connector „3” positioner)

i This function is not available for **APIS-1XX-....** executions. Drawing facilitating identification of chamber A of the actuator is presented in the Fig.16.

- o Set the **PRESS. A** function using buttons Δ or ∇ buttons, e.g.:

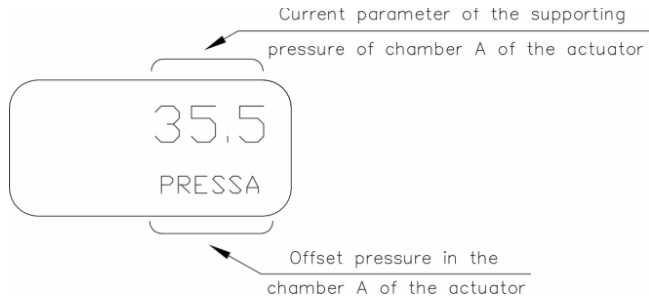

- o Press the button \leftarrow ; the following will appear on display:

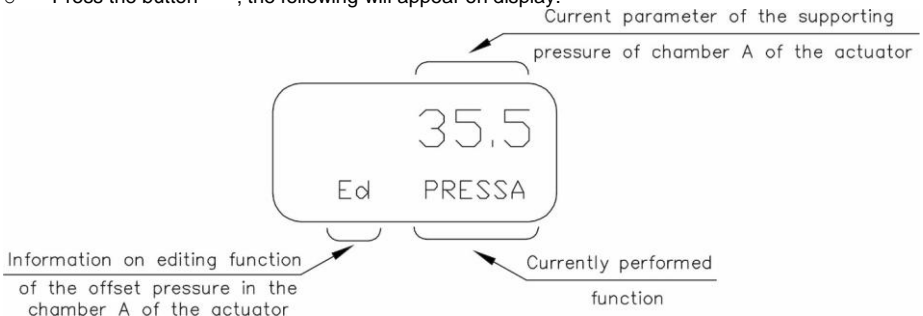

- If you do not intend to change chamber A's pressure, press the \leftarrow button; the following menu function will appear on display, i.e., **PRESSb** - see section 11.2.3.16.
- If the user intends to change the value of the pressure in the chamber A of the actuator, it is necessary to press or/and hold the button Δ or button ∇ , observing the pressure on the pressure gauge attached to connection "2" of the positioner. The value of this pressure should be between 30 - 70 % supply pressure of the positioner.
- Confirm the set value **PRESSA** pressing the button \leftarrow ; the following will appear on display, e.g.:

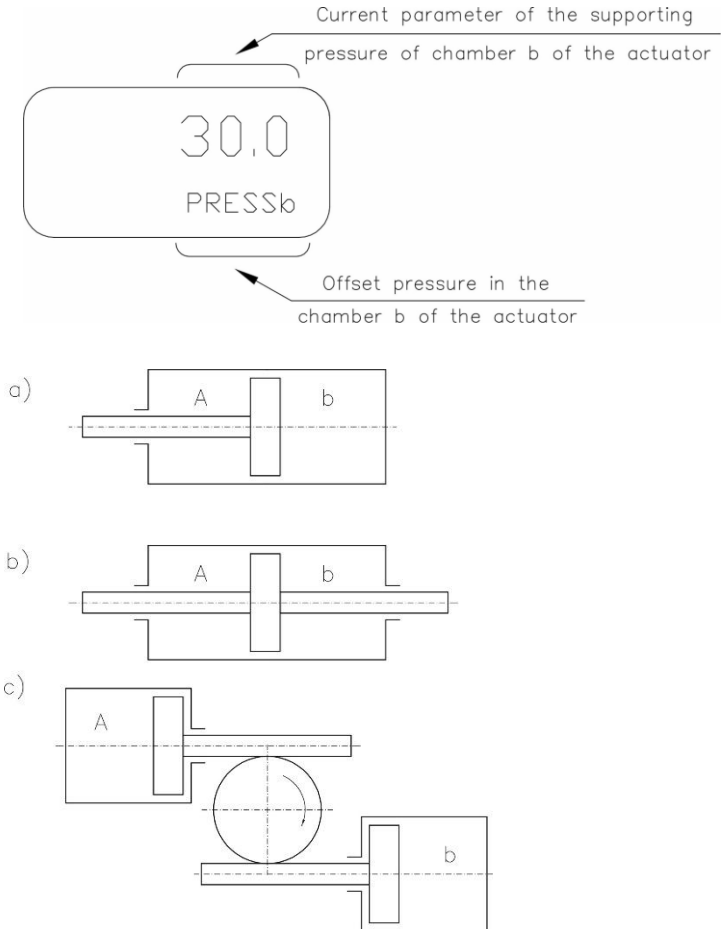

Fig. 16. Identification of support chambers of double-acting actuators
 a) with linear movement with single-acting piston rod
 b) with linear movement with double-acting piston rod
 c) with rotational movement



Offset pressure of chamber A of the actuator **PRESSA** is determined automatically during the implementation of the **AUTO** function – see section 11.2.3.2.

11.2.3.16. **PRESSb** – offset pressure of chamber b of the actuator (chamber connected with connector „2” positioner)



This function is not available for **APIS-1XX-....** executions. Drawing facilitating identification of chamber b of the actuator is presented in Fig. 16.

- Set the **PRESSb** function using Δ or ∇ buttons, e.g.:

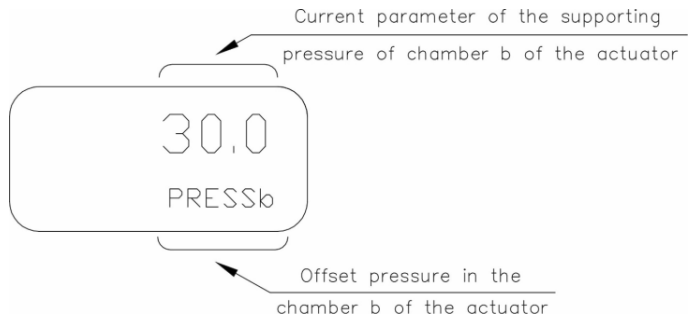

- Press the button \leftarrow ; the following will appear on display:

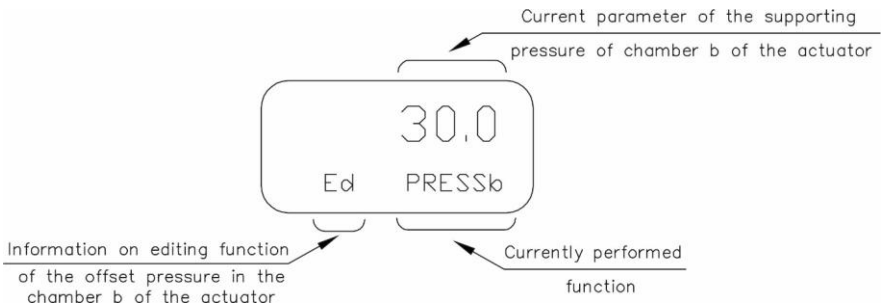

- If you do not intend to change chamber b's pressure, press the \leftarrow button; the following menu function will appear on display, i.e., **LIMITL** - see section 11.2.3.17.
- If the user intends to change the value of the pressure in the chamber b of the actuator, it is necessary to press or/and hold the button Δ or button ∇ , observing the pressure on the pressure gauge attached to connection “3” of the positioner. The value of this pressure should be between 30 - 70 % supply pressure of the positioner.

- Confirm the set value **PRESSb** with the button \leftarrow ; the following will appear on display, e.g.:

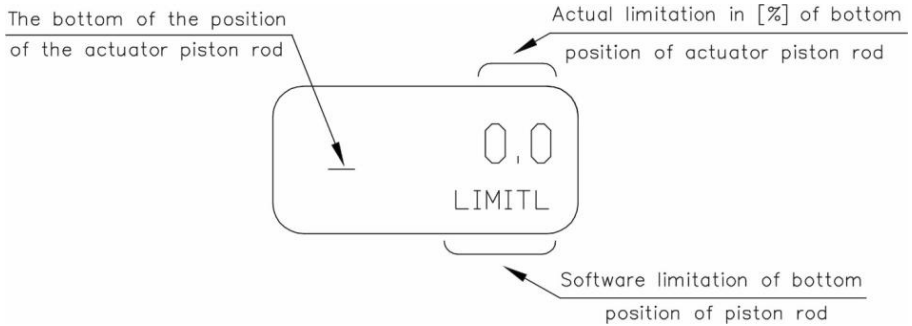

Supporting pressure of chamber b of the actuator **PRESSb** is determined automatically during the implementation of the function **AUTO** – see section 11.2.3.2.

11.2.3.17. **LIMIT L – set by software the lower limit of piston rod position**

- Set the **LIMITL** function using Δ or ∇ buttons, e.g.:

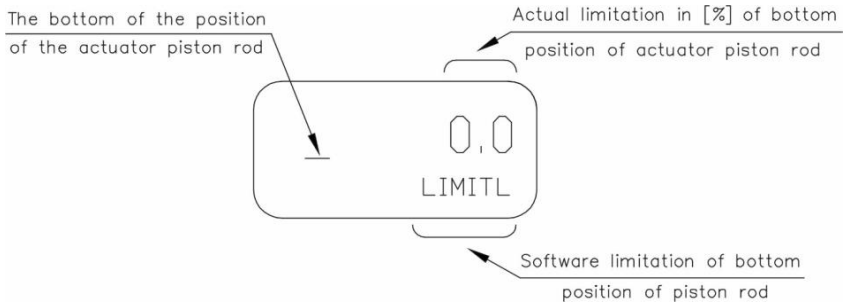

- Press the button \leftarrow ; the following will appear on display:

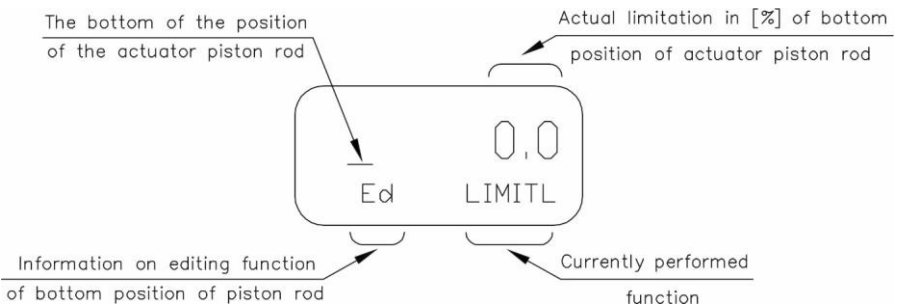

- If the user does not intend to change the lower limit of the stem position, press the \leftarrow button; the following function level will appear on display, i.e., **LIMITH** - see section 11.2.3.18.
- Press and/or hold the button Δ or ∇ for changing the lower limit of the stem position.
- Confirm the set value **LIMITL** with the button \leftarrow ; the following will appear on display, e.g.:

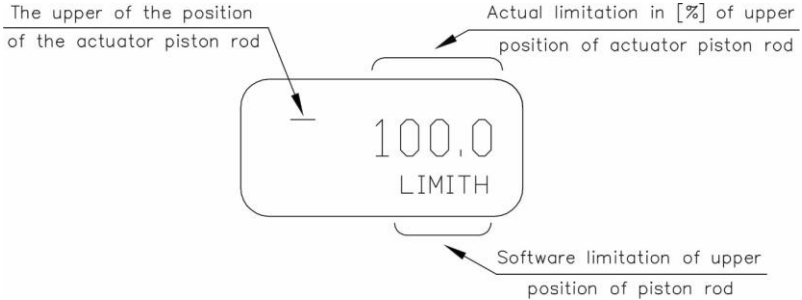

By default, the limitation of the bottom range of position of piston rod of the actuator is set to 0%. The **LIMITL** function does not work when the **CLAMPL** function is activated at the same time.

11.2.3.18. **LIMITH** – set by software the upper limit of piston rod position

- Set the **LIMITH** function using Δ or ∇ buttons, e.g.:

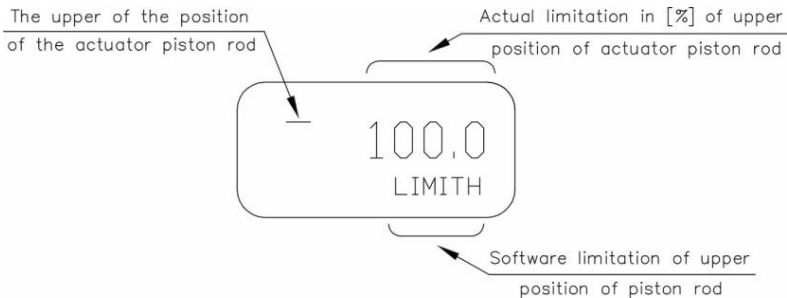

- Press the button \leftarrow ; the following will appear on display:

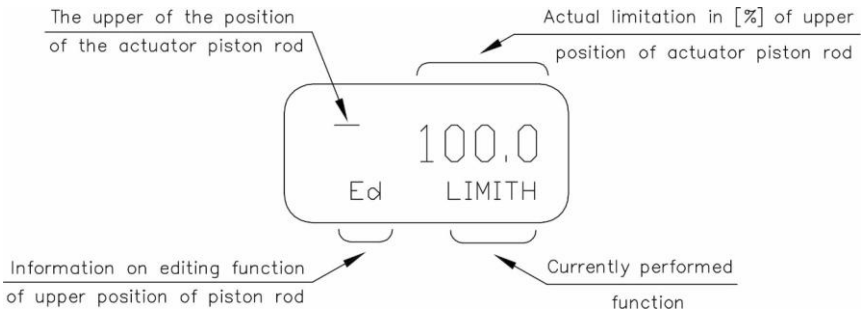

- If the user does not intend to change the lower limit of the stem position, press the $\leftarrow \downarrow$ button; the following function level will appear on display, i.e., **CLAMPL** - see section 11.2.3.19.
- Press and/or hold the button Δ or ∇ for changing the lower limit of the stem position.
- Confirm the set value **LIMITH** with the button $\leftarrow \downarrow$; the following will appear on the display e.g.:

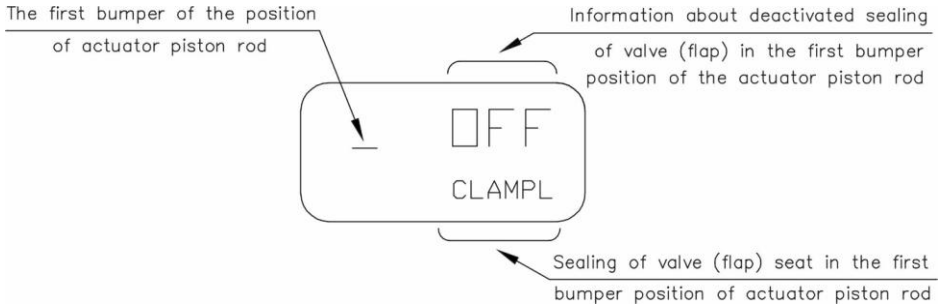

By default limitation for upper range of position of actuator piston rod is set to 100%. The **LIMITH** function does not work when the **CLAMPH** function is activated at the same time.

11.2.3.19. **CLAMPL** - clamping of valve (flap) seat in the first bumper position of the actuator piston rod

- Set the **CLAMPL** function using Δ or ∇ buttons, e.g.:

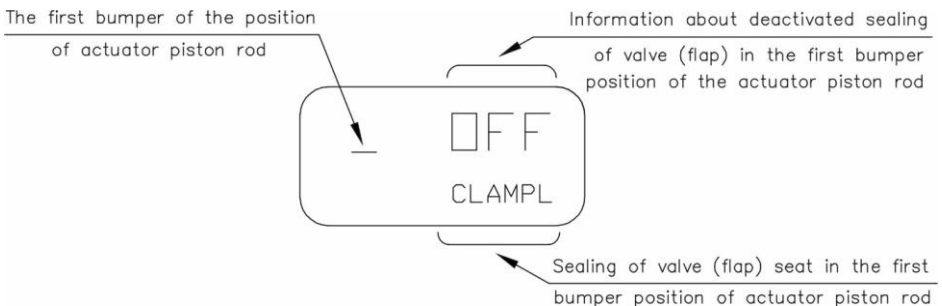

- Press the button \leftarrow ; the following will appear on display:

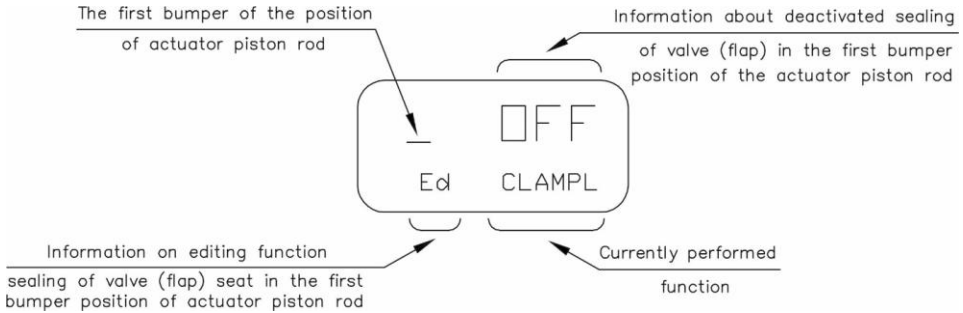

- If the user does not intend to activate valve (flap) clamping function in the first bumper position of the actuator piston rod then he/she should press the button \leftarrow ; the following menu function will appear on display, i.e., **CLAMPH** - see section 11.2.3.20.
- If the user intends to activate valve (flap) clamping function in the first bumper position of the actuator piston rod then he/she should press the button ∇ or Δ once; then the following will appear on the display:

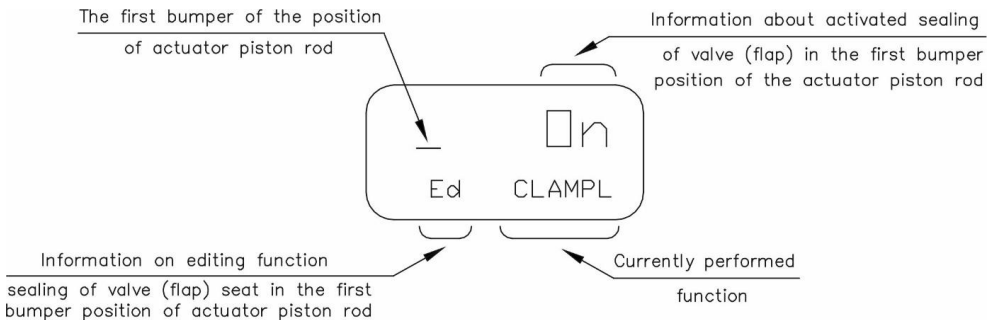

- Confirm the activation of valve (flap) seat clamping function in the first bumper position of actuator piston rod by pressing the button \leftarrow ; the following will appear on display, e.g.:

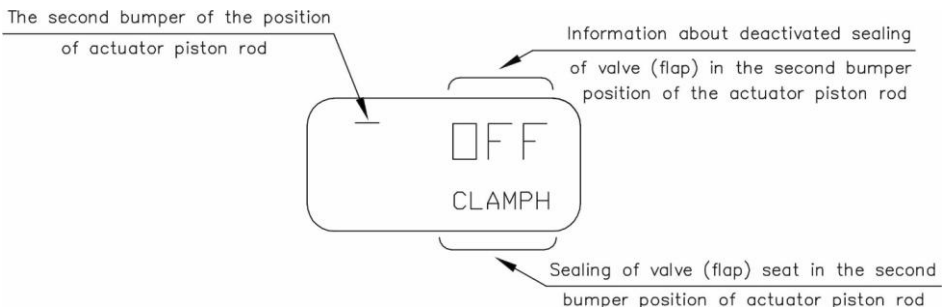

Clamping of valve (flap) seat in the first bumper position of the actuator piston rod is factory set as switched (**OFF**).

11.2.3.20. CLAMPH - clamping of valve (flap) seat in the second bumper position of the actuator piston rod

- o Set the **CLAMPH** function using Δ or ∇ buttons, e.g.:

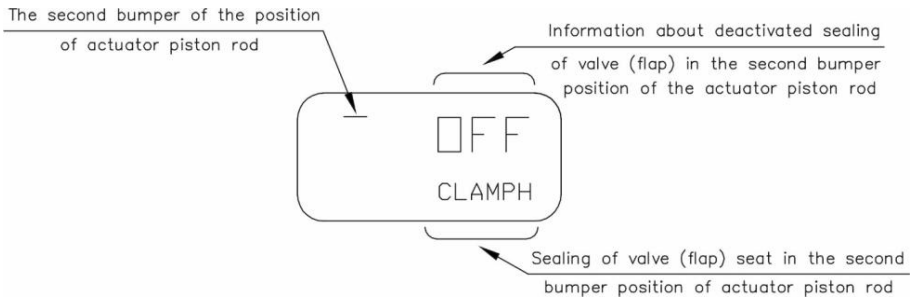

- o Press the button \leftarrow ; the following will appear on display:

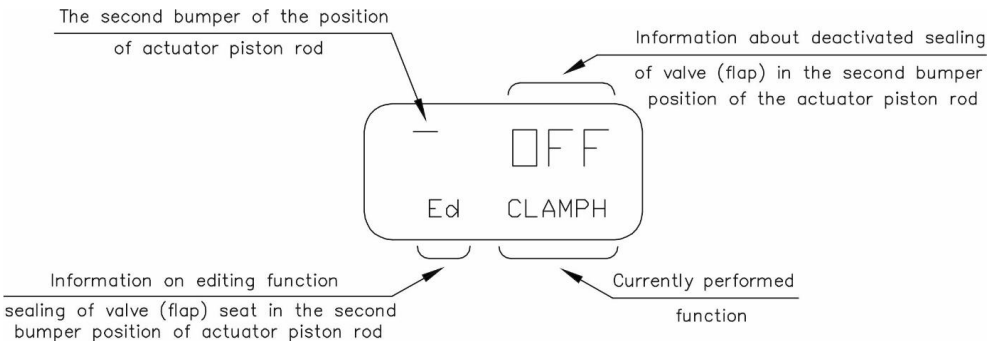

- o If the user does not intend to activate the valve (flap) clamping function in the second bumper position of the actuator piston rod then he/she should press the button \leftarrow ; the following menu function will appear on display, i.e., **LIMSWI** - see section 11.2.3.21.
- o If the user intends to activate the valve (flap) clamping function in the second bumper position of the actuator piston rod then he/she should press the button ∇ or Δ once; then the following will appear on the display:

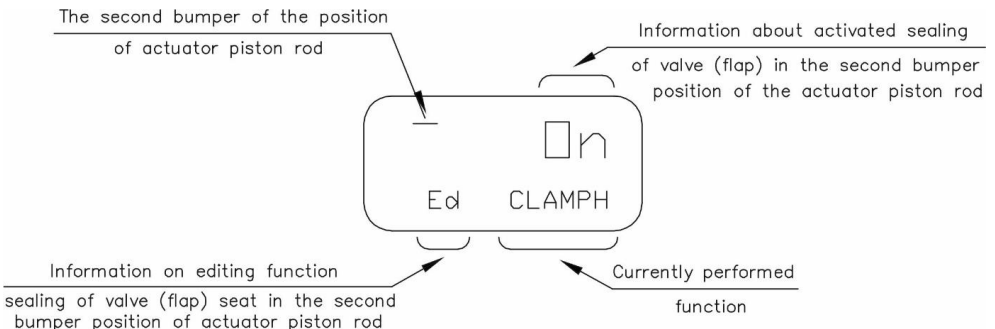

- Confirm the activation of valve (flap) seat clamping function in the second bumper position of actuator piston rod by pressing the button \leftarrow ; the following will appear on display, e.g.:

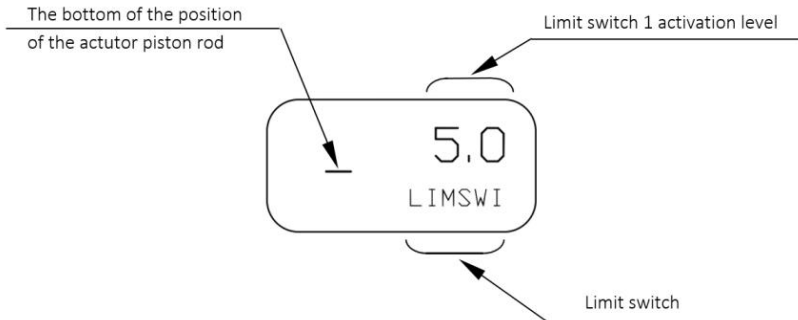

Clamping of valve (flap) seat in the second extreme position of the actuator piston rod is factory set as switched (**OFF**).



11.2.3.21. _ **LIMSWI** – lower limit switch activation level – no.1

- Set the **_LIMSWI** function using Δ or ∇ buttons, e.g.:

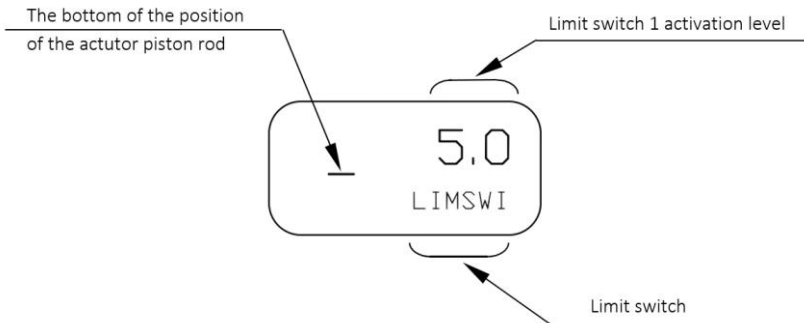

- Press the button \leftarrow ; the following will appear on display:

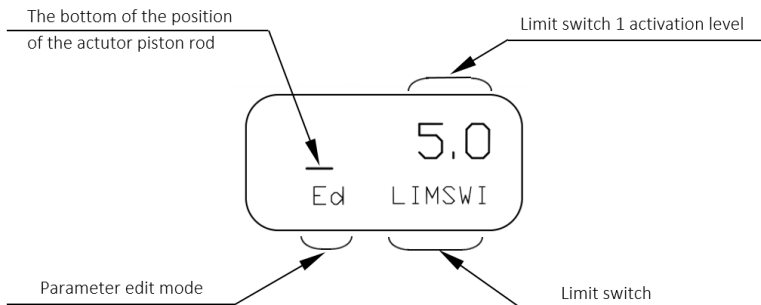

- If the user does not intend to change the limit switch 1 activation level, press the \leftarrow button; the following function level will appear on display, i.e., **_LIMSWI** - see section 11.2.3.22.

- Press and/or hold the button Δ or ∇ for changing the limit switch 1 activation level.
- Confirm the set value **LIMSWI** with the button \leftarrow ; the following will appear on display, e.g.:

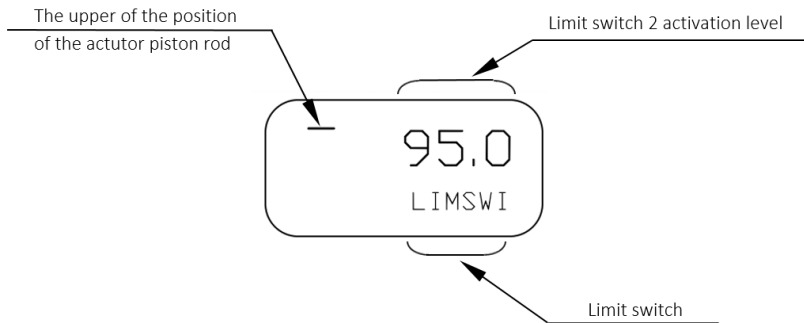

11.2.3.22. $\bar{\text{LIMS WI}}$ – upper limit switch activation level – no.2

- Set the $\bar{\text{LIMS WI}}$ function using Δ or ∇ buttons, e.g.:

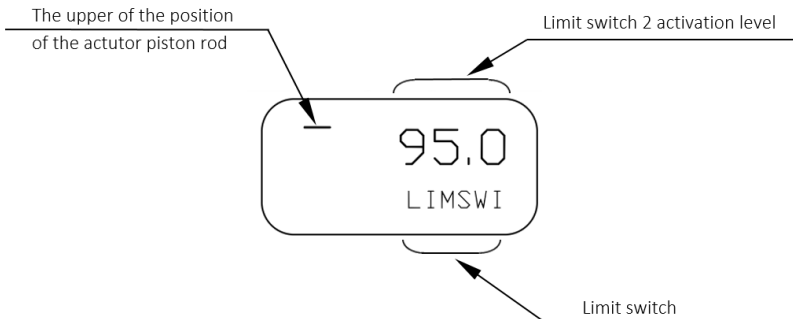

- Press the button \leftarrow ; the following will appear on display:

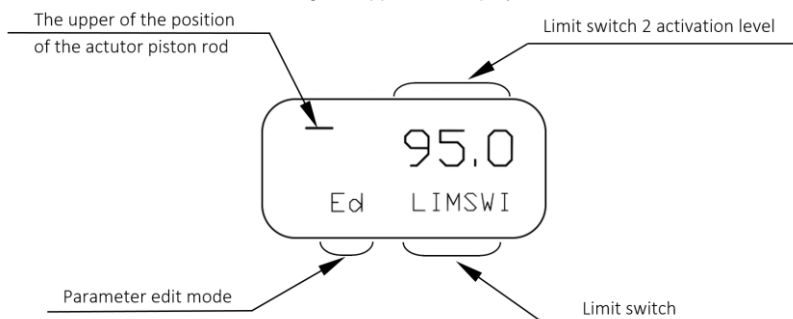

- If the user does not intend to change the limit switch 2 activation level, press the \leftarrow button; the following function level will appear on display, i.e. **NEWPIN** - see section 11.2.3.23.
- Press and/or hold the button Δ or ∇ for changing the limit switch 2 activation level.
- Confirm the set value $\bar{\text{LIMS WI}}$ with the button \leftarrow ; the following will appear on display, e.g.:

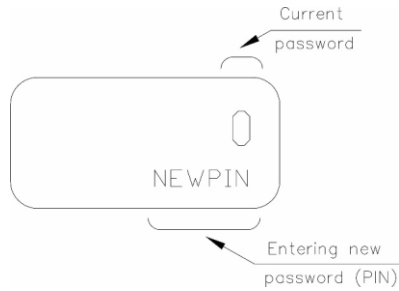

11.2.3.23. NEWPIN – entering a new numerical password (PIN)

- o Set the **NEWPIN** function using Δ or ∇ buttons, e.g.:

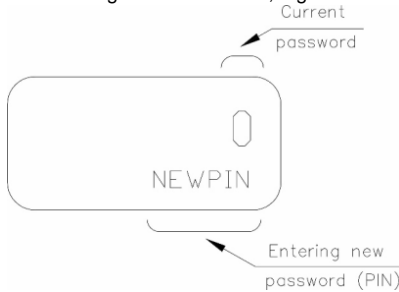

- o Press the button \leftarrow ; the following will appear on display:

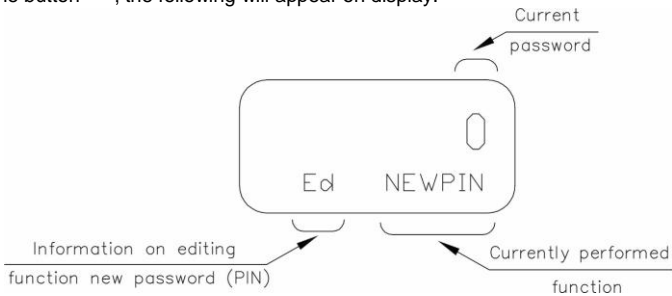

- o The numerical values of new password (according to the wish of the user) should be set by pressing and/or holding the button Δ , or ∇ .

i Factory set value for **PIN - 0**. Maximum number of characters - 4.

Press the button \leftarrow after entering the new PIN; the following will appear on display:

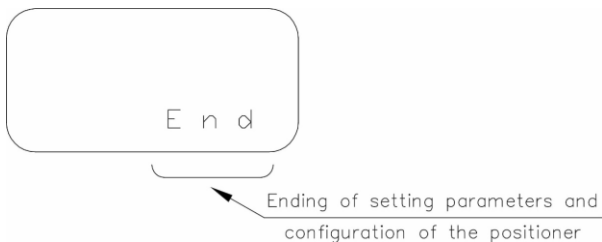

11.2.3.24. End – the end of settings of the parameters and configuration of the positioner

- o Set the **End** function using buttons Δ or ∇ :



Ending of setting parameters and configuration of the positioner

The user should press the button \leftarrow ; to finish entering parameters and configuration of the positioner; then the following will appear on the display e.g.:

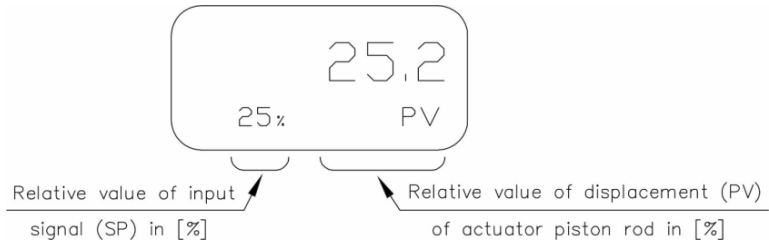

This information indicates the 1st service level (normal operation mode) of the positioner.

The user should press the button ∇ to continue setting the parameters and configuration of the positioner ; then the following will appear on the display e.g.:

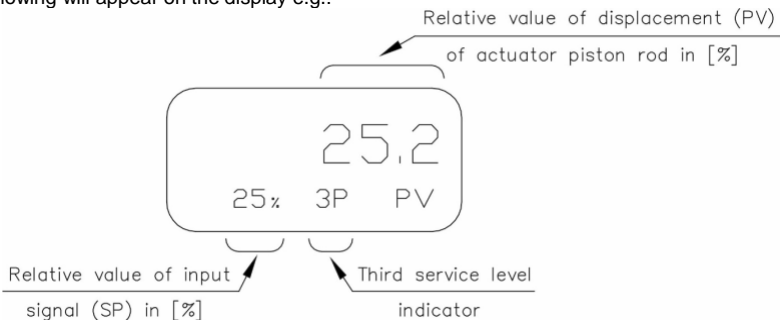

The above information indicates that we are at the top of the third service level.

11.3. Starting positioner - actuator assembly



Do not rub plastic components of the positioner in hazardous areas during works related to the positioner due to the possibility of accumulation of static charges.

- a) Positioner APIS-1X0... installed on the actuator acc. to point 10.2...10.4. should be connected with the measuring system acc. to the diagram presented in Fig. 17.

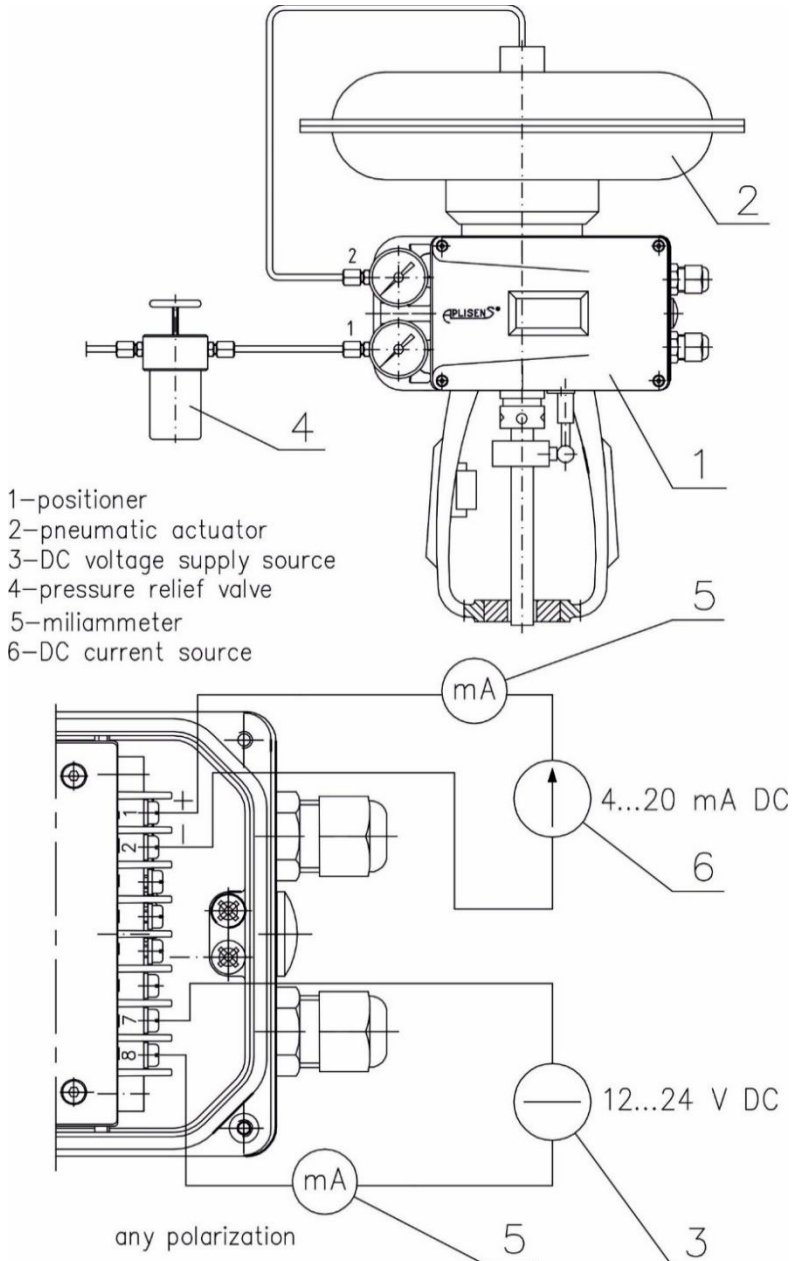

Fig. 17. Diagram of measuring circuit for starting APIS-1X0... positioner (single-acting membrane actuator)

- Positioner APIS-1X0-... and APIS-2X0-... installed on the actuator acc. to sect. 10.5. should be connected acc. to the diagram presented in Fig. 18.

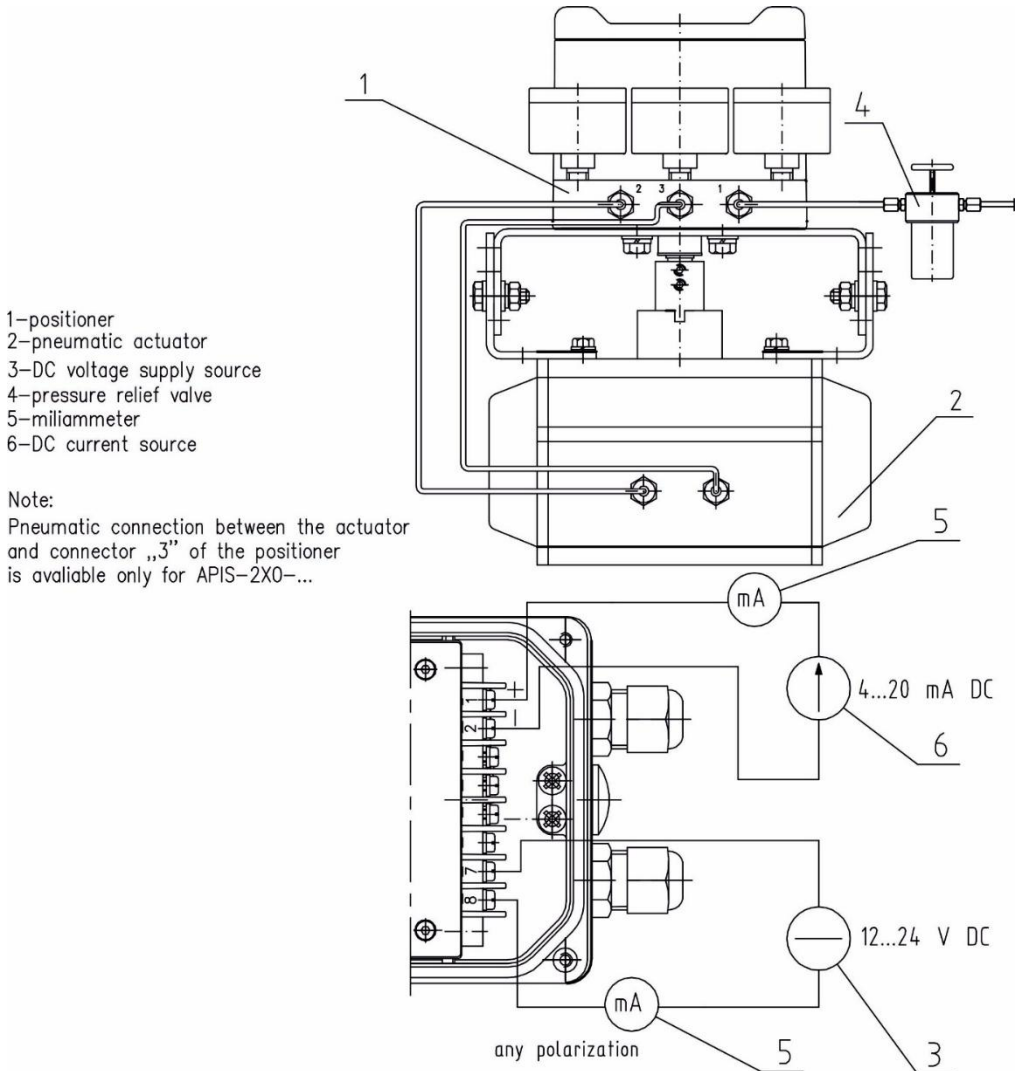

Fig. 18. Diagram of wiring for launching APIS-1X0-... and APIS-2X0-... positioners single/double-acting rotary actuator)

- Positioner APIS-2X1-... and APIS-2X2-... installed on the actuator acc. to sect. 10.6. should be wired acc. to the diagram presented in Fig. 19.

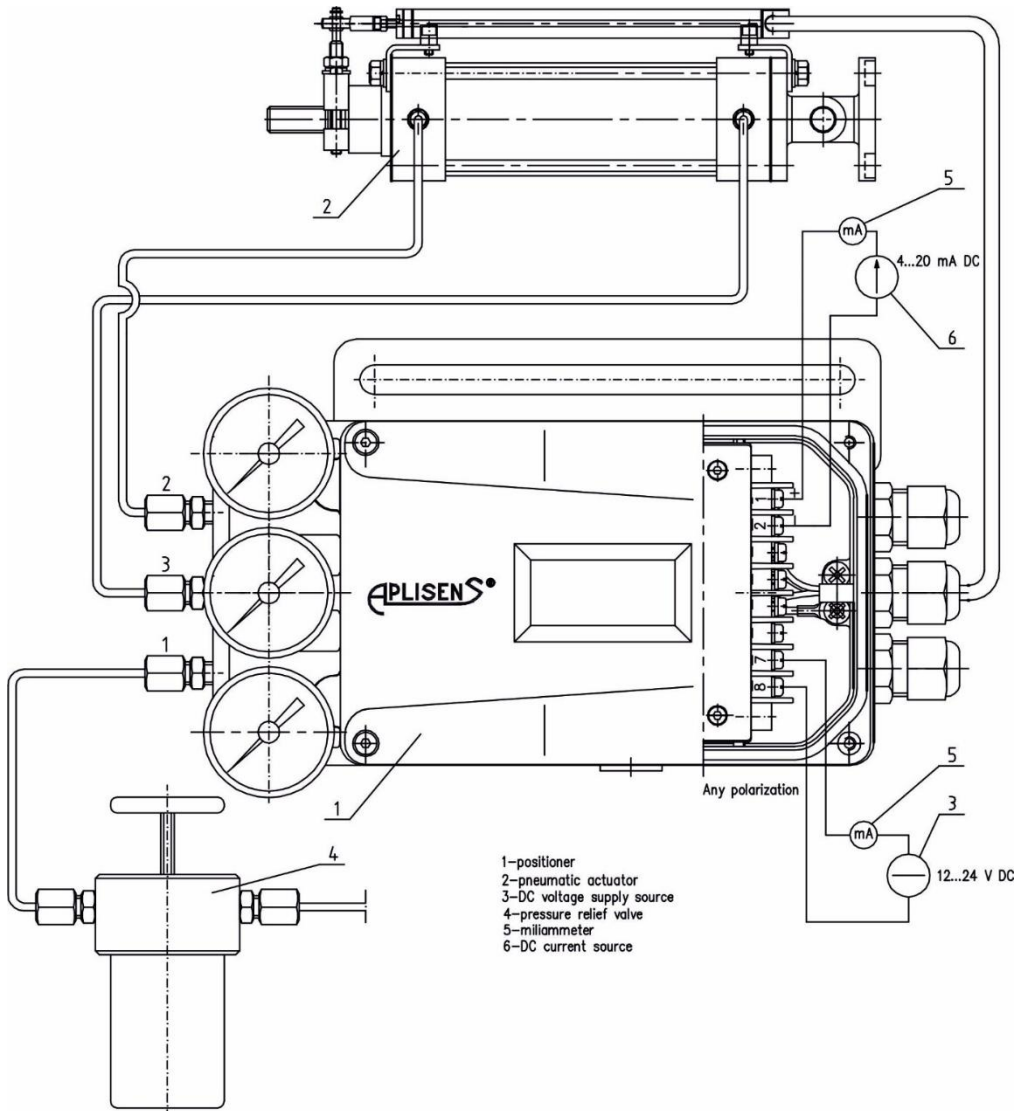

Fig. 19. Diagram of wiring circuit for launching APIS-2X1-... and APIS-2X2-... positioner (linear double-acting actuator)

- Positioner APIS-2X0-... installed on the actuator acc. to sect. 10.7. should be wired acc. to the diagram presented in Fig. 20.

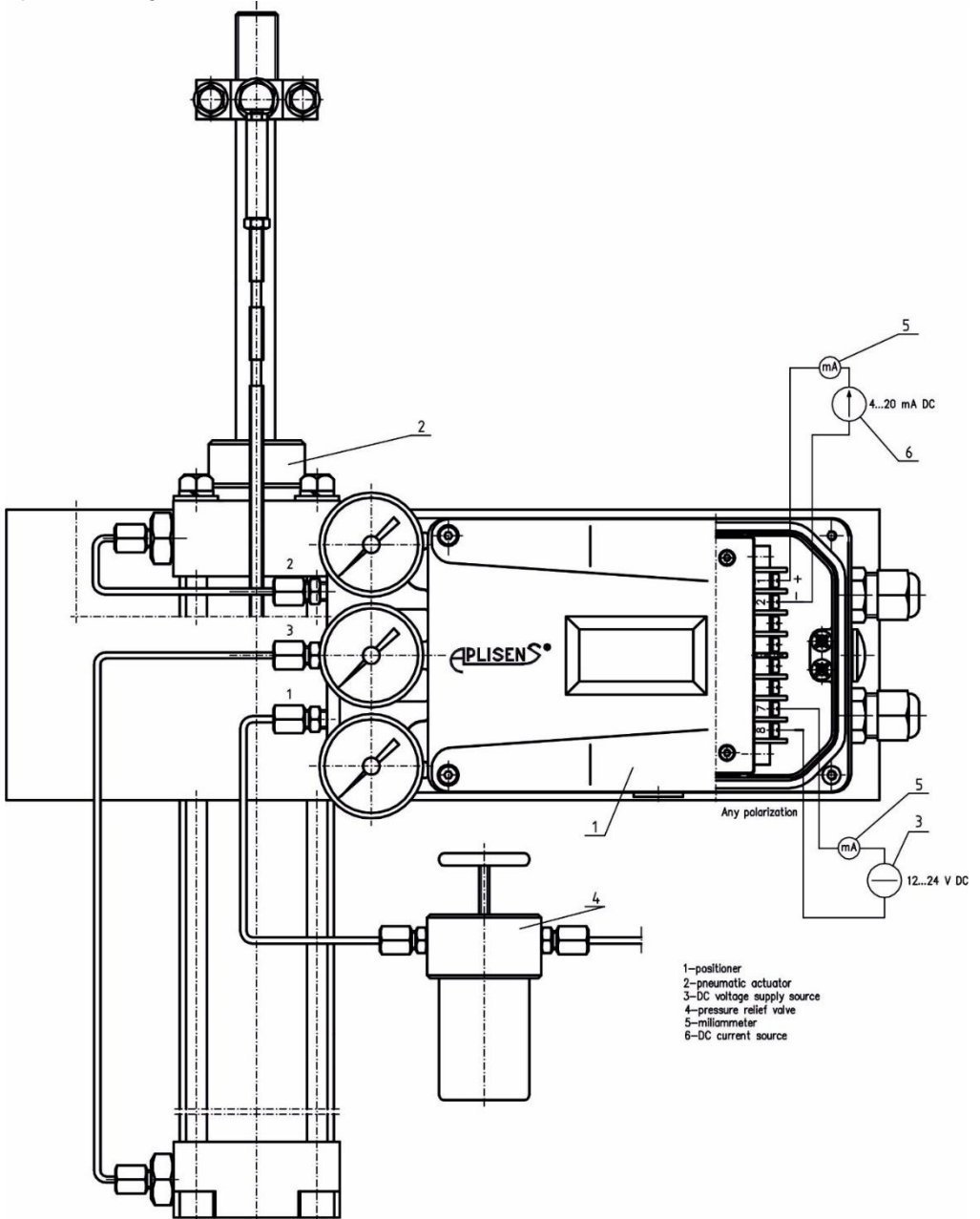
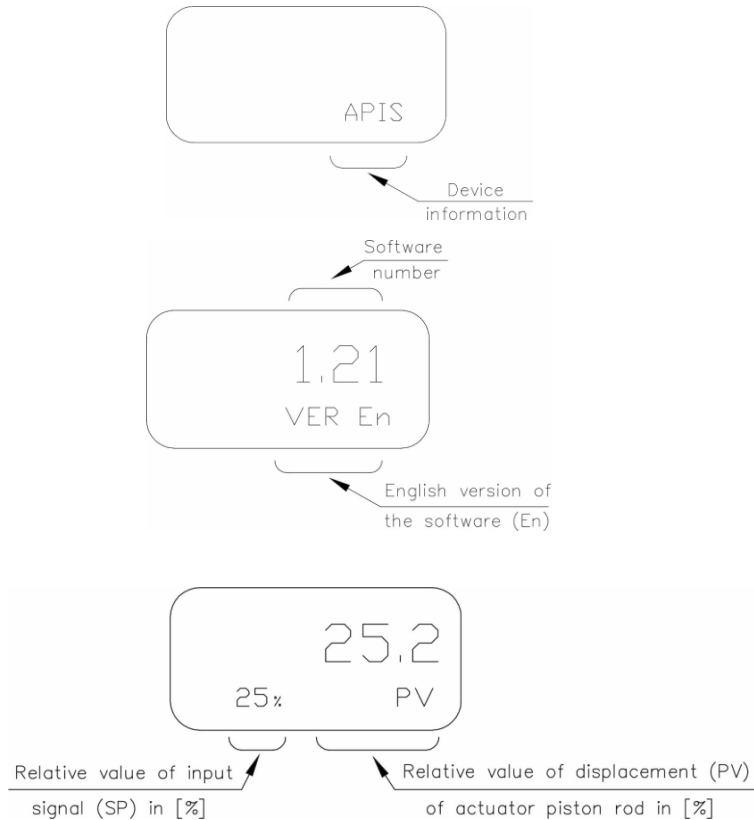

Fig. 20. Diagram of wiring circuit for APIS-2X0-... positioner (linear double-acting actuator)

- b) Apply input signal with value $8 \pm 0,5$ mA DC from the current source. After that, it will appear on the display following sequence:



This information indicates that the positioner is at the I (1st) service level (normal operation mode).

- c) Set the supply pressure for an actuator to e.g. 140 kPa using the pressure controller.
 d) Then switch to the second service level. For this purpose, press the buttons Δ and ∇ at the same time. The display will show:

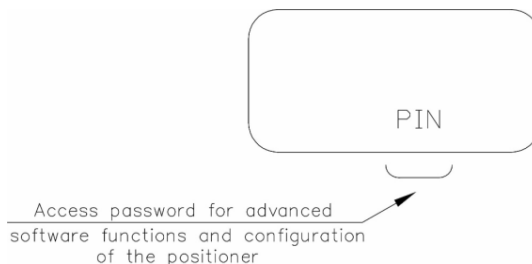

- Press the button \leftarrow ; the following will appear on the display:

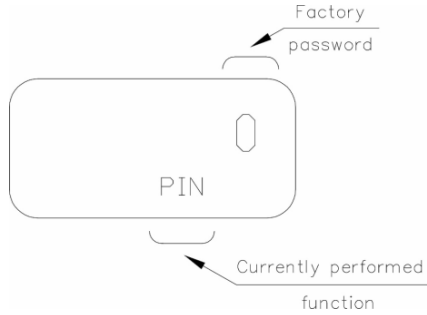

If the factory password has been already changed then it should be set using buttons Δ and ∇ .

- Confirm the password with a button \leftarrow ; the following will appear on the display:

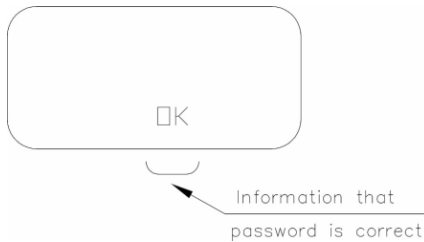

Above texts will disappear from the positioner display after approx. 1 s. Then the following will be displayed e.g.:

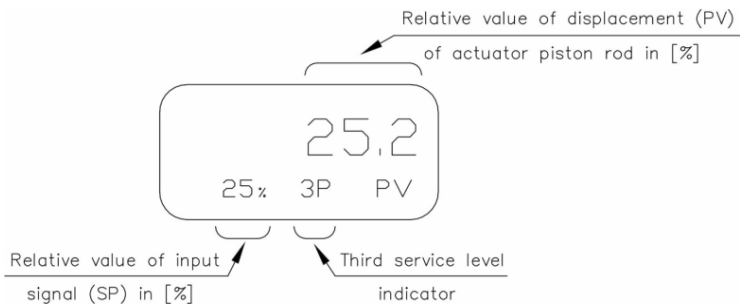

The above information indicates that we are at the third service level of the positioner (parameters setting and configuration mode).

- Press the button \leftarrow once; the following will appear on the display:

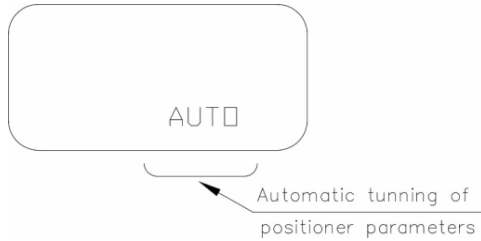

- Press the button \leftarrow ; the following will appear on the display:

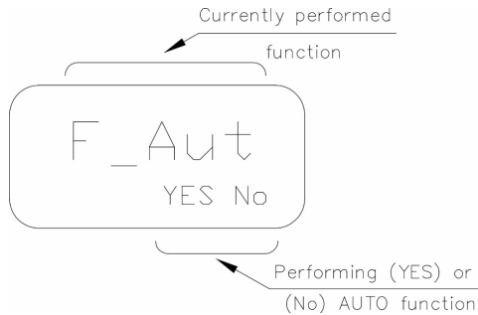

Press the button Δ :

Wait for ending the operation of the automatic tuning of for the positioner.

After completion of automatic tuning of positioner parameters, the following will appear e.g.:

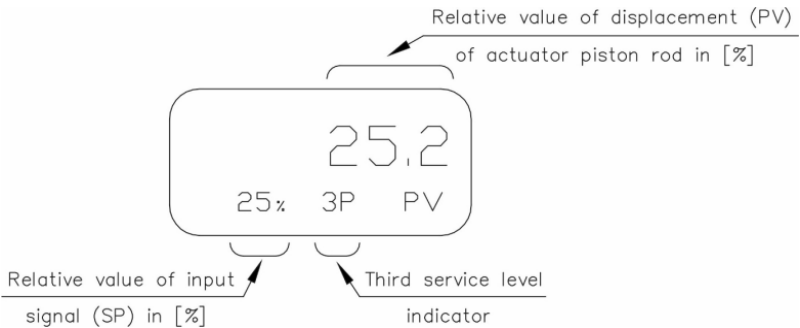

- o Press the button Δ once; the following will appear on the display:



Ending of setting parameters and configuration of the positioner

- o Press the button \leftarrow ; the following will appear on the display e.g.:

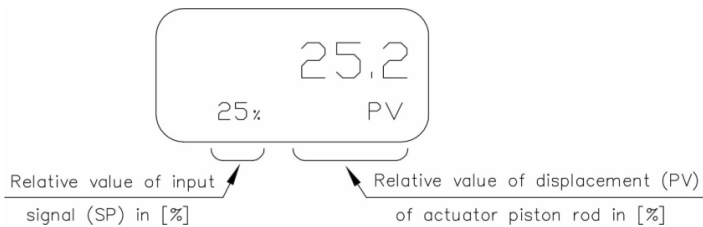

The above information indicates that we are at the first service level of the positioner.

- e) Current programming device item 6 – e.g.: Fig. 17 decrease input signal to 4 ± 0.01 mA DC; the following will appear on the display e.g.:

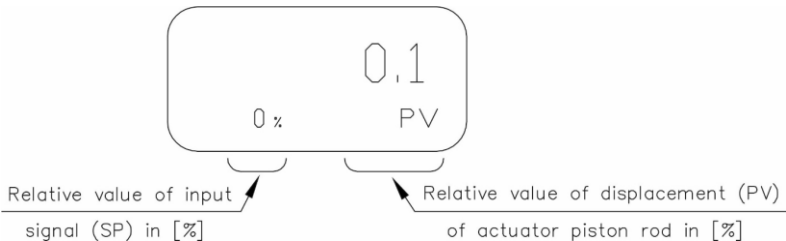

Relative value of displacement **PV** of actuator piston rod on the display should be equal to $0 \pm 0.4\%$.

- f) Check operation of the positioner by changing input signal in the range 4...20 mA DC. It should include smoothness of operation and lack of stops and vibrations. If this condition is not fulfilled then the user should adequately correct the parameters of the **PID** controller that is parameters **k_p** , **T_i** , **T_d** , and additionally **RAMP** parameter.

In the case of executions **APIS-2XX-...**, the **PRESSA** and **PRESSb** parameters should also be corrected accordingly.

11.4. Electrical connections of the positioner

Electrical wiring diagram in the Fig. 21a)...e) (depending on version of the positioner).



Unused electrical gland during normal operation should be replaced with blanking component (plug) enclosed to the positioner.

11.4.1. Electrical wiring diagram of positioner for the executions with build-in (internal) displacement transducer applies for executions APIS-XX0-....

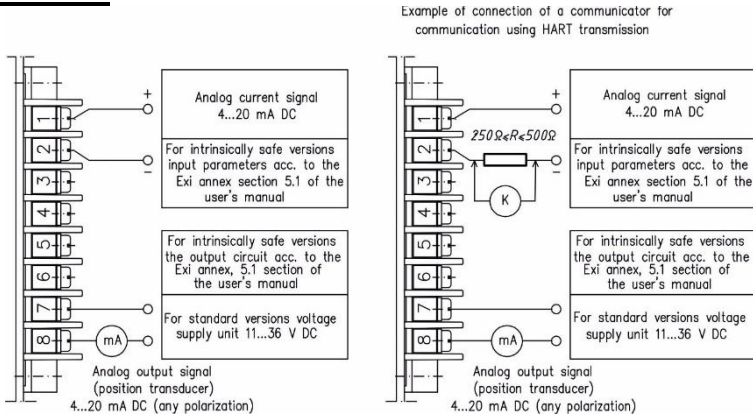

Fig. 21a. Electrical wiring diagram of the positioner's version with build-in displacement (position) transducer

11.4.2 Electrical wiring connections of the positioner for execution with external displacement transducer (applies for executions APIS-XX1-..., APIS-XX2-..., APIS-XX4-...)

In case of executions of positioner with external position transducer it is strongly recommended to carry out the electrical connections accordingly to the following rules:

- The only one terminal of the shield of the cable of the displacement transducer must be connected with terminal #2 of the positioner as in Figures 21b, c, d, e;
- If the shield of the cable of potentiometer is connected galvanically to potentiometer's case (Fig. 21c) then the potentiometers case should not be grounded (in order to disrupt current loop).
- If the second terminal of the shield of the cable is separated from potentiometer's case (Fig. 21b) then it is recommended to connect positioner's and potentiometer's cases by means of external wire.

In remaining cases (Fig. 21d, e) the electrical connection between both cases is ensured by the common grounding.

Example of connection of a communicator for communication using HART transmission

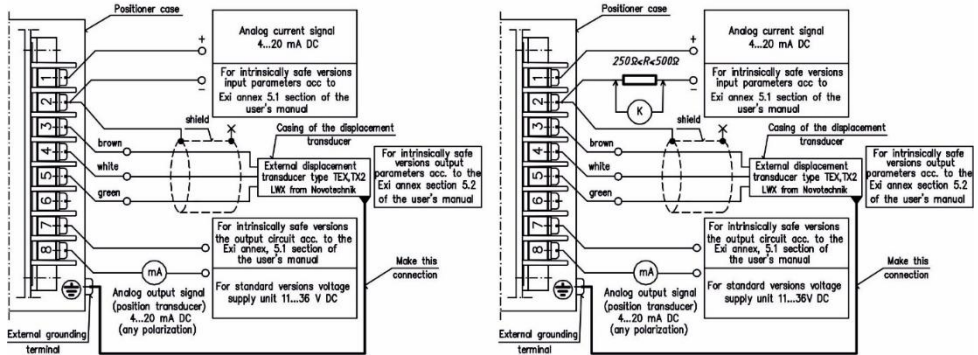

Fig. 21b Wiring position for executions with an external displacement transducer if:

- The shield of the potentiometer cable is disconnected from the case of the potentiometer;
- The displacement transducer and positioner are galvanically isolated. Please note that in this case is necessary to connect both cases by means of an external wire

Example of connection of a communicator for communication using HART transmission

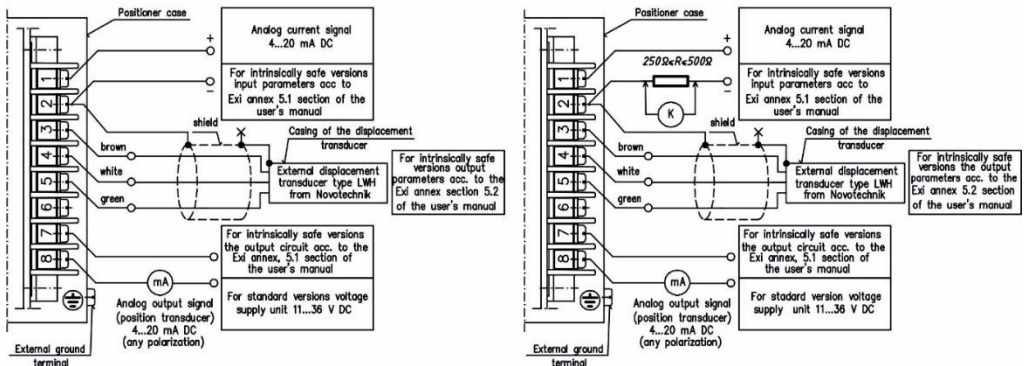

Fig. 21c Wiring of positioner for the executions with an external displacement transducer if:

- The shield of the potentiometer cable is galvanically connected with the case of potentiometer;
- The potentiometer and positioner cases are electrically separated

Example of connection of a communicator for communication using HART transmission

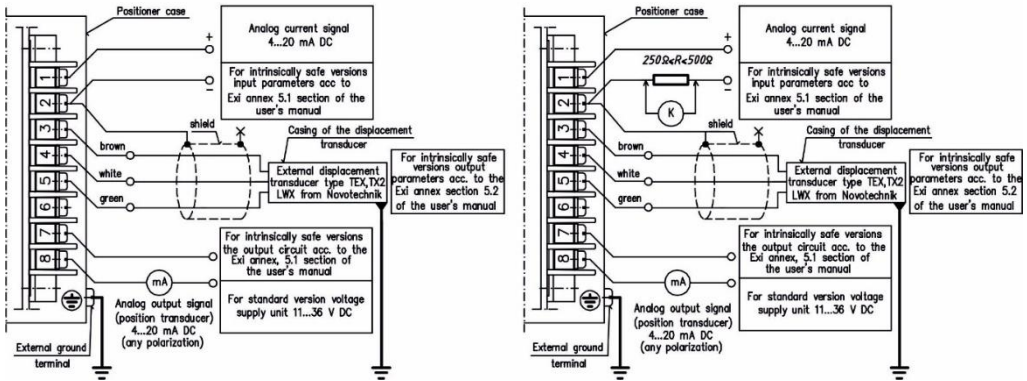

Fig. 21d Wiring of positioner for the executions with an external displacement transducer if:

- The shield of the potentiometer cable is galvanically disconnected with the case of potentiometer;
- The potentiometer and positioner cases are electrically separated

Example of connection of a communicator for communication using HART transmission

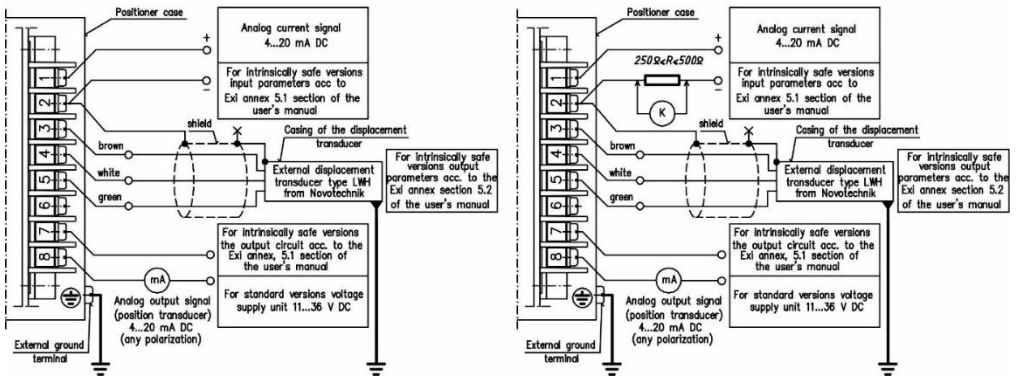

Fig. 21 e Wiring diagram of the positioner for executions with an external displacement transducer if:

- The shield of the cable is galvanically connected with the case of potentiometer;
- The potentiometer and positioner cases are electrically connected and grounded

11.4.3 Electrical wiring connections of the positioner for execution with limit switches (applies for versions APIS-XX0-...-S2, APIS-XX0-...S3)

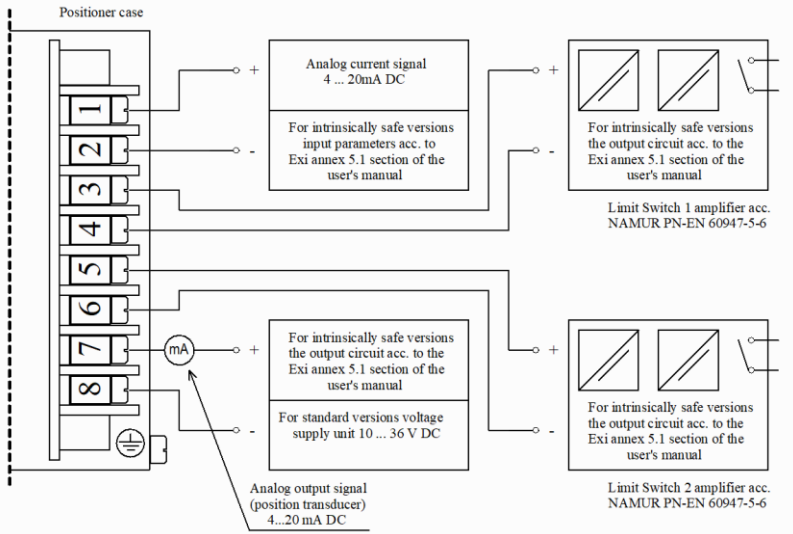

Fig. 21 f Wiring diagram of the positioner for executions with two S2 type limit switches

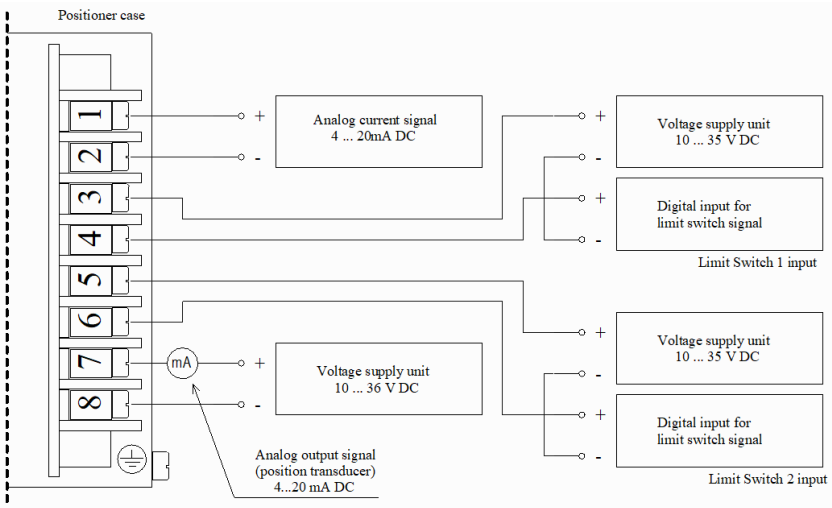

Fig. 21 g Wiring diagram of the positioner for executions with two S3 type limit switches

11.5. Operation

Correctly installed positioner and set for operation does not require any servicing during operation except the periodic maintenance. The condition for correct operation is proper preparation of supply air in accordance with the requirement given in the section 7.

11.6. Disassembly of the positioner

If it is necessary to dismount the positioner:

- a) Reduce the supply pressure to zero;
- b) Shutdown the current input signal (control);
- c) Disconnect electrical conductors of the input signal and pneumatic conductors of supply pressure and output from the positioner, secure pneumatic tips of the positioner against the contamination
- d) Undo fixing screws and remove the positioner with support from the actuator or structural component, on which the positioner was installed (applies to APIS-1X0-... with mounting kit APIS-A0001-SS or SO and APIS-A0002-SS or SO
- e) Disassemble from the actuator:
 - extension arm set with clamping rings (applies to APIS-1X0-... with mounting kit APIS-A0001-SS or SO and APIS-A0002-SS or SO
 - board set with clamping rings (applies to APIS-1X0-... with mounting kit APIS-A0000-SS or SO and APIS-A0003-SS or SO
 - support (applies to APIS-1X0-... and APIS-2X0-... with mounting kit APIS-A0050-SS or SO
 - two supports, linear displacement transducer, extension arm and clamping ring (applies to APIS-2X1-... version with mounting kit APIS-2X1-AXXXX-SS or SO.
- f) Components disassembled in point e) should be fixed to the positioner in a way preventing loosening them further storage and possible packaging of the positioner for shipment should conform the requirements given in chapter 8 and 9.

12. MAINTENANCE

Check tightness of the pneumatic hoses every six months or more often and tighten nuts on the connectors. Detected leaks should be immediately eliminated. The user should maintain periodic inspections of filtering equipment located in the supply line of the positioner to ensure adequate cleanness of working medium.

13. FAILURES AND REPAIRS

Table 2 Troubleshooting

| No. | Damage | Causes of damage | Removal method |
|-----|---|--|--|
| 1 | Incorrect indications of the supply pressure gauge | Supply reducer damaged or shutdown Defective pressure gauge | Damage outside the positioner Replace pressure gauge |
| 2 | Incorrect indications of the output pressure gauge | Defective pressure gauge | Replace pressure gauge |
| 3 | No indications on the positioner display | Source of input signal damaged or shutdown Input signal cables damaged. Input signal below 3.2 mA | Damage outside the positioner. Replace cables. Damage outside the positioner |
| 4 | The positioner does not respond to changes of input signal Output pressure equal to zero | Faulty or missing connection between electropneumatic or displacement transducer and electronic controller. Leakage between the body of the positioner and the input chamber of the actuator or the electropneumatic converter. | Replace damaged connector or connect correctly. Remove leaks |
| 5 | Actuator does not respond to changes of output pressure from the positioner | Cable connecting positioner with actuator damaged or crushed. Actuator or valve seized, | Replace the cable. Damage outside the positioner |
| 6 | Unstable operation of the actuator (vibrations of actuator piston rod) | Too high gain coefficient k_p value, too low value of integral action time T_i , Leaky actuator | Decrease gain coefficient k_p of the controller (see sec. 11.2.3.3), increase integral action time of the controller (see sec. 11.2.3.4) Damage outside the positioner. |
| 7. | Too slow displacement of the actuator piston rod | Too high value of time constant RAMP of actuator piston rod. Too high pressure in chamber A or b or both chambers of the actuator | Decrease value of time constant RAMP of actuator piston rod (see point 11.2.3.6) Decrease value PRESS A (see sec. 11.2.3.15), PRESS b (see sec. 11.2.3.16) |
| 8. | Too quick displacement of the actuator piston rod | Too low value of time constant RAMP of actuator piston rod. Too low pressure in chamber A or b or both chambers of the actuator. | Increase value of time constant RAMP of actuator piston rod (see sec. 11.2.3.6) Increase value PRESS A (see sec. 11.2.3.15), PRESS b (see sec. 11.2.3.16) |
| 9 | The message SorrY by the execution of the AUTO or STROKE functions. | Too low supply pressure. Electro-pneumatic transducer fault. | Check the shut-off valve in the installation or the pressure reducing valve. Replace electropneumatic transducer (s). |



All repairs should be carried out by the manufacturer or authorized service. The manufacturer shall not be responsible for safety and correct operation of the product in case of repairs carried out by the third parties.

14. SPARE PARTS

Table 3 List of spare parts

| Item No. acc. to the Fig. 22. | Part name | Drawing no. (Ordering code) | Notes |
|-------------------------------|---|--|---|
| 1 | Electropneumatic converter | APIS-H001-100 | Applies to APIS-XXX-...-RSt-... |
| 2 | Electronic unit | APIS-B121-110 | Applies to: APIS-1X0-...-RSt-... |
| | | APIS-B121-100 | Applies to: APIS-2X0-...-RSt-... |
| | | APIS-B122-210 | Applies to: APIS-1X4-...-RSt-... |
| | | APIS-B122-200 | Applies to: APIS-2X1-...-RSt-... and APIS-2X2-...-RSt-... |
| | | APIS-B121-300 | Applies to: APIS-2X3-...-RSt-... |
| 4 | Pressure gauge - housing made of acid resistant steel, glass pane | M40T-2,5-NPT1/8"; 0-1MPa | Applies to: APIS-XXX-...-RSt-...-M2-... |
| 5 | Pressure gauge made of acid resistant steel, glass pane | RCh 40-3rm, rear central connector, range 0...1 MPa. | Applies to: APIS-XXX-...RSt-...-M3... |
| 6 | Sealing | APIS-H001-200 | Applies to APIS-XXX-...-RSt-... versions |
| 7 | Linear displacement converter | APIS-H005-... or APIS-H006-... | Not visible on Fig. 22, applies to APIS-2X1-...-RSt-... Please provide stroke and diameter of actuator piston rod during ordering |
| 8 | Sealing | ON 145x3 | Applies to APIS-XXX-...-RSt-... versions |

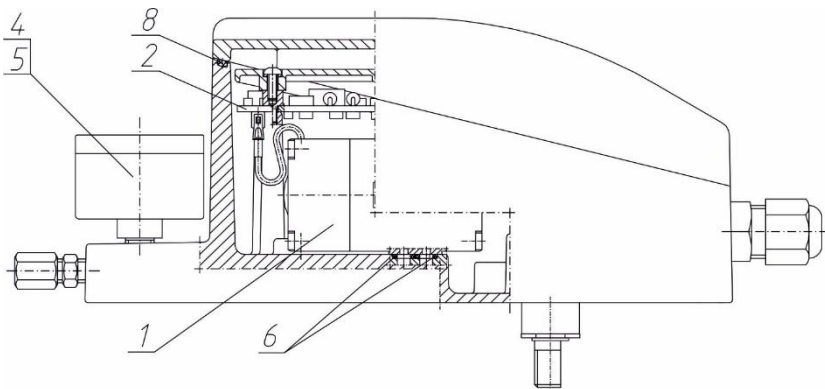

Fig. 22. Positioner type APIS. Location of the spare part

